

miniDriller®

DM901HDE

DIESEL ELECTRIC



HIGH RELIABILITY



LOW MAINTENANCE



SAFE



DESIGNED FOR THE TOUGHEST APPLICATION



A SIMPLE AND RELIABLE MINIDRILLER

The DM901 HDE is a Front face drilling rig, driven by a Diesel engine and drilling by an Electric powerpack with a cable reel.

Designed to match perfectly the Aramine miniLoader range, the DM901 miniDrill uses many common components from the hydraulic components to the tire size, but also the same overall dimensions with the unique width of 1,05 m.

Compact and easy to maneuver, the Boom allows drilling in 1,7m wide up to 3m wide galleries, which makes the DM901 miniDrill the only machine in the market able to mechanize small sections as 4m².

The HDE version is fitted for Horizontal Face drilling, but the DM901 is also available in Vertical Long Hole drilling.

Like all Aramine Equipment, the DM901 is tough and simple machine designed for underground environment, and especially for the very narrow vein mines.

The carrier is a strong welded frame with 4 wheel drive and central articulation.

The rear axle is oscillating, and the center of gravity is low for better stability.

YOUR OFFICIAL AUSTRALIAN DISTRIBUTORS



www.SITECHWA.com.au
Sales@SITECHWA.com.au
08 9392 7700

PERTH
1/8 Hasler Road
Osborne Park WA 6017



www.SmartTechAustralia.com.au
Reception@SmartTechAustralia.com.au
1800 655 860

BRISBANE
4/29 Links Avenue North
Eagle Farm QLD 4009

TOWNSVILLE
11-13 Casey Street
Aitkenvale QLD 4814

SYDNEY
13/7-9 Progress Circuit
Prestons NSW 2170

MELBOURNE
11B The Crossway
Campbellfield VIC 3061

TASMANIA
PO BOX 315
Newstead TAS 7250



Aramine joins the Global Compact of the United Nations and is committed to develop its Social Responsibility



 Leader in mining and underground solutions

miniDriller®

DM901HDE

DIESEL ELECTRIC

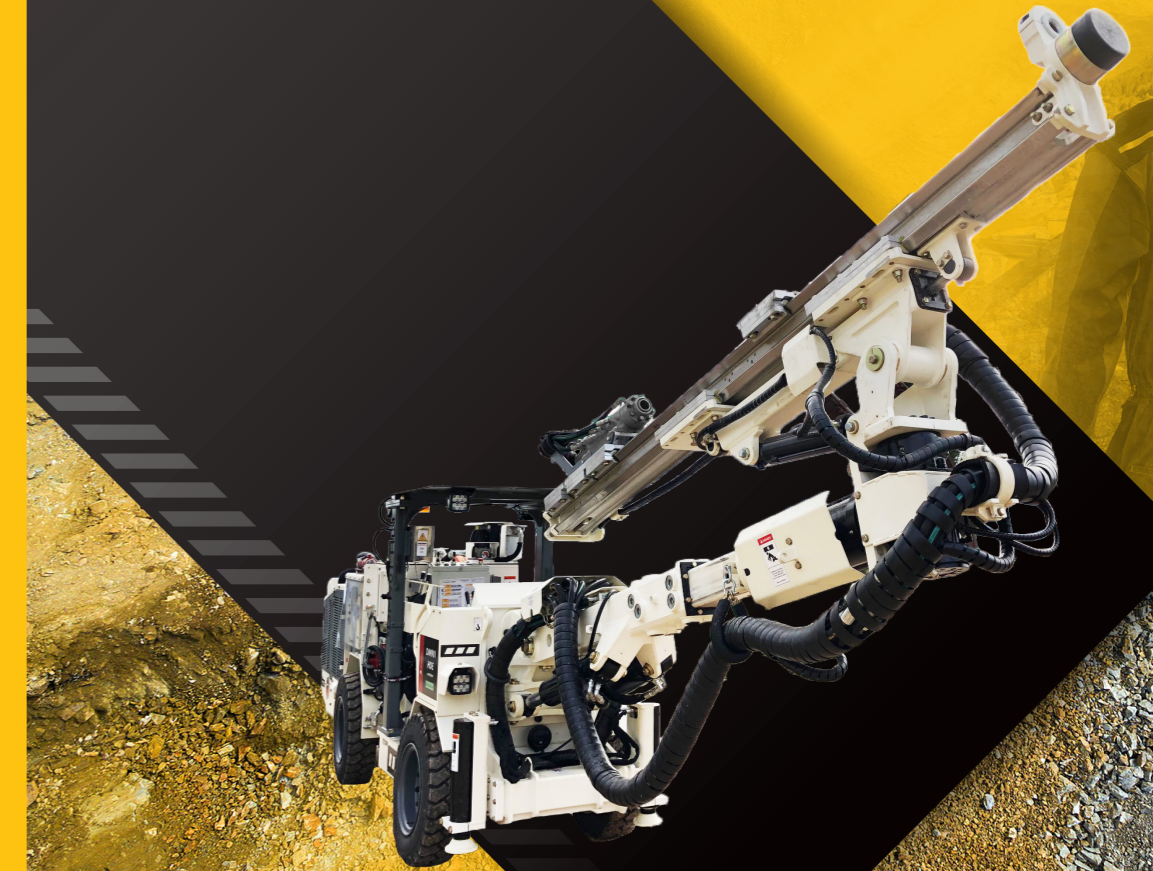

Narrow



Productive



Robust



Safe

DIESEL DRIVEN & ELECTRIC DRILLER



DM901HDEENG 06.2019 - RCS 304 692 171 000 75

DIMENSION AND DRILLING COVERAGE

CARRIER SPECIFICATIONS

- 4WD heavy duty carrier, articulated, rear axle oscillating
- FOPS certified canopy over operator
- Deutz engine, series TD2011 52 kW @ 2300 rpm, TIER 3
- Air intake : Dry Type Air cleaner
- Engine Exhaust : Catalytic Purifier with silencer
- Transmission : Hydrostatic transmission with 4 wheel end motors
- Brake System : Hydrostatic Brake system
- Parking Brake : Spring applied hydraulic release in each wheel motor
- Tires : 7.5 x R15 for underground application
- Central Articulation with Locking device
- Two Front Hydraulic stabilizers with width extension
- Cable Reel for 60 m electrical cable
- Hydraulic system with Bowman Cooler
- Ansul Fire suppression system
- (1) Fire extinguisher
- Manual centralized Lubrication
- Engine Hourmeter in Dashboard and Drilling Hourmeter In electrical Cabinet.
- Working lights : 2 x Front LED Light N44, 50W, 24 V
- Tramming lights : 2 Front and 2 Rear Led Lights
- Tramming Speed : Horizontal Ground : 7 Km/h
Incline 14% : 5 Km/h

RECOMMENDED DRIFT SIZE

- (Canopy mounted)

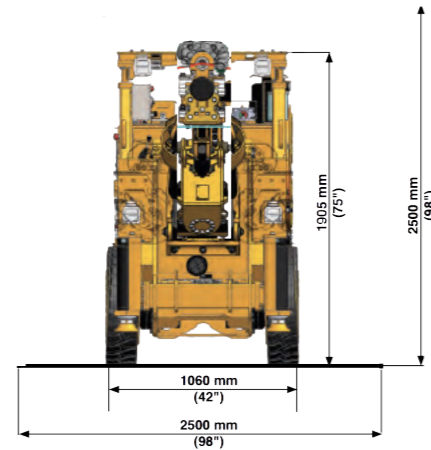

DRIFTER

| Drifter | Montabert HC25 | Epiroc RR14 |
|-------------------|---------------------|------------------|
| | Standard | Option |
| Percussion power | 7,5 kW | 11 kW |
| Percussion press | 150 bar | 180 bar |
| Rotation speed | 0-250 rpm | 0-300rpm@125cc |
| Hole diameter | 45-64 mm | 51-64 mm |
| Lub Air cons. | 300L/min | 400L/min |
| Length with shank | 703 mm (R32F) | 750 mm |
| Percussion Freq. | 65 Hz | 70 Hz |
| Rotation torque | 313 Nm | 510 Nm@125cc |
| Shank adapter | R32 Female-T38 Male | R32 |
| Water cons. | 20-50L/mn (15bar) | 25-50L/mn(15bar) |
| Weight | 73 kg | 81 kg |

ELECTRIC SYSTEM

- Protection degree IP55
- Electric motor 55 kW (75 HP)
- Standard Voltage & Frequency: 400V50Hz or 440V60Hz (Other voltage on demand)
- Starting method: Star - Delta Overload
- Protection & ground fault: VIGI Module
- Phase sequence indicator: Siemens
- Electric cable reel with bushing type collector 60m cable 4x35mm

AIR SYSTEM

- Standard Air Compressor
- Hydraulically driven 5,1L/s (10,8 CFM)
- Working pressure 3 bar

BOOM

- 1x BUA9F Boom for 4 to 9 m² Section
- (1,7 width x 2.2m High up to 3x3m)
- Telescopic Boom
- Angle lift +45°/-20°
- Swing angle +30°
- Rotary cylinders for vertical and horizontal rotation, 360° and 220°
- Hydraulic cylinders with Pilot check valves

FEED

- Standard Model HUA 220 aluminium Feed with cable, pulley & cylinders style 700mm
- Advance Drilling 700mm

| | Unit | HUA180 | HUA200 | HUA220* | VUA110 |
|------------------|------|--------|--------|---------|--------|
| Total Length | mm | 3000 | 3200 | 3400 | 2200 |
| Hole Length | mm | 1800 | 2000 | 2200 | 1000 |
| Rod Steel Length | mm | 2000 | 2200 | 2400 | 1200 |

* STANDARD (Optional Telescopic Feeds - See back for details)

WATER

- Standard Water Pressurizer
- Hydraulic driven Water pump
- Maximum capacity 6,9m³/h
- Mini inlet press 2 bar

DM90IHDE DIESEL ELECTRIC

ARAMINE DM90IHDE miniDriller® DRILLING POSITION

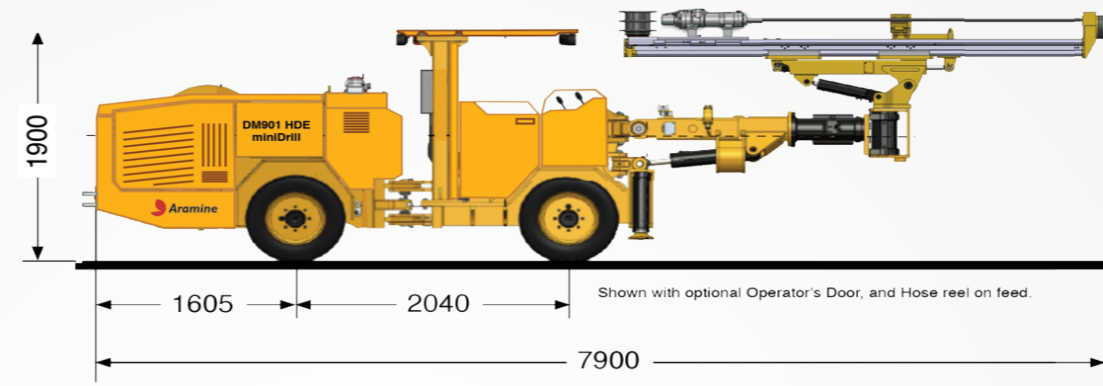

Width : 1.05 m

Height : 1.90 m / Length for Transportation : 7,50 m

Weight (Operationnal) : 7,1 t

Parts, Operation and maintenance in PDF and USB key

SELECTION OF OPTIONAL TELESCOPIC FEED

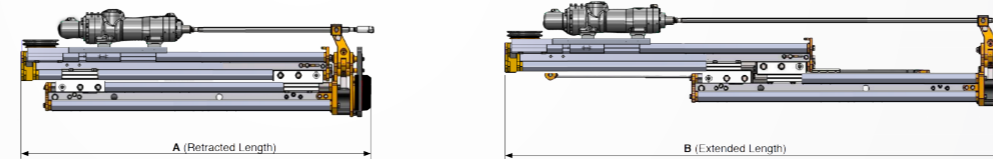

| Aramine Feed Model | Length A Retracted (mm) | Length B Extended (mm) | Drill rod Retracted | Drill rod Extended | Max Drill Hole* Bolt Length |
|--------------------|-------------------------|------------------------|---------------------|--------------------|-----------------------------|
| THUA 8-10 | 3330 | 3930 | 8'R32 | 10'R32 | 8'(2,4m) |
| THUA 7-9 | 3010 | 3620 | 7'R32 | 9'R32 | 7'(2,1m) |
| THUA 6-10 | 2710 | 3930 | 6'R32 | 10'R32 | 6'(1,8m) |
| THUA 5-8 | 2410 | 3320 | 5'R32 | 8'R32 | 5'(1,5m) |
| THUA 4-7 | 2020 | 3010 | 4'R32 | 7'R32 | 4'(1,2m) |

* with Montabert HC Drifter

DRILLING SYSTEM

- 1x Hydraulic/Electric Powerpack 55kW-60Hz or 45 kW - 50Hz
- Direct Drilling controls from operator's compartment, with regulators valves
- Easy Manual Drilling Regulation with gage indicators
- Possibility to use percussion without rotation for Bolting

OPTION

- Ansul Fire suppression System
- Operator's Door with park brake interlock
- Radio Remote Control
- Telescopic Feed for Bolting or confined area
- Epiroc RR14 (14kW) drifter

The drawings and images of this brochure may show equipment with specific options.
The specifications and equipment are subject to change without notice.

ARAMINE DM90IHDE miniDriller® TRAMMING POSITION

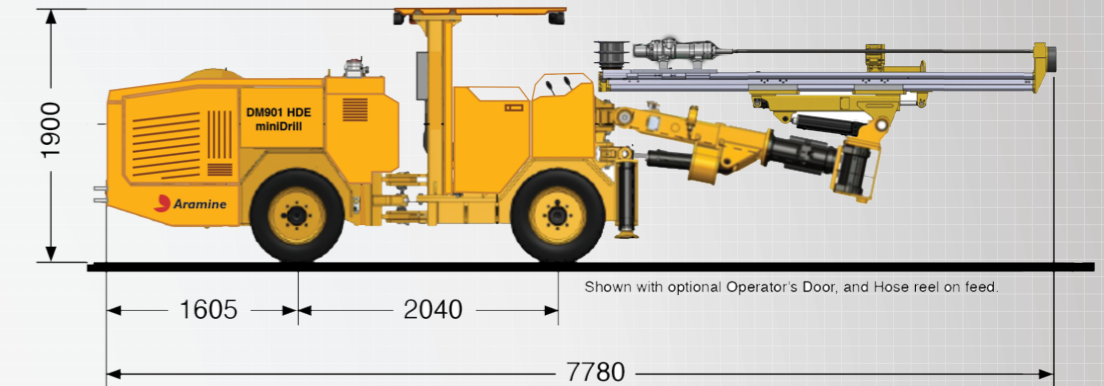

Total Boom coverage
Maxi Section Coverage
Mini Section Coverage

