

# USER MANUAL

## Trimble LOADRITE L2180 Loader Scales

Software 60364 | 60454 | 60504  
Version 2.77  
Revision A  
February 2019  
ENGLISH

111142-95-ENG





# Trimble LOADRITE L2180

## User manual

Software Number: 60364 | 60454 | 60504  
Version Number: 2.77

Document Number: 111142-95-ENG  
Revision: A

Issued Date: February 2019

E: [info@loadritescales.com](mailto:info@loadritescales.com)  
W: [www.loadritescales.com](http://www.loadritescales.com)

© 2019 Trimble Inc. All rights reserved. Trimble, the Globe & Triangle logo are trademarks and/or registered trademarks of Trimble Inc, registered in the United States and in other countries. Loadrite is a trademark and/or registered trademark of Trimble Inc. All other trademarks and registrations are the property of their respective owners.





The software contains proprietary information of Trimble Inc; it is provided under a license agreement containing restrictions on use and disclosure and is also protected by copyright law. Reverse engineering of the software is prohibited.

This document is copyrighted with all rights reserved. Under copyright laws, this document may not be copied in whole or in part, reproduced in any other media, stored in a retrieval system, or transmitted in any form or by any means, electronic, mechanical, photocopying, recording or otherwise, without the express written permission of Trimble Inc. Permitted copies must carry the same proprietary and copyright notices as were affixed to the original. Under the law, copying includes translation into another language.

Published in New Zealand.

# Important safety information

PLEASE READ CAREFULLY BEFORE USING THE LOADRITE™ WEIGHING SYSTEM

	This is the safety alert symbol. It is used to alert you to potential personal injury hazards. Obey all safety messages that follow this symbol to avoid possible injury or death.
	<b>WARNING</b> indicates a potentially hazardous situation which, if not avoided, could result in death or serious injury.
	<b>CAUTION</b> indicates a potentially hazardous situation which, if not avoided, may result in minor or moderate injury.
	<b>CAUTION</b> used without the safety alert symbol indicates a potentially hazardous situation which, if not avoided, may result in property damage.



It is your sole responsibility to place, secure and use the LOADRITE Weighing System in a manner that will not cause accidents, personal injury or property damage. Always observe safe operating practices.

Do not install the LOADRITE Weighing System in a way that may interfere with the safe operation of the vehicle, or deployment of safety equipment.

Before you use the LOADRITE Weighing System for the first time, familiarize yourself with the system and its operation.



Do not handle any part of the LOADRITE Weighing System if it is hot. Let the product cool, out of direct sunlight.

Ensure that the LOADRITE Weighing System is connected to a power source with the correct fitting and voltage requirements.

Do not attempt to service the LOADRITE Weighing System as this could result in personal injury.



Removing LOADRITE Weighing System equipment or adding accessories could affect the accuracy of weighing data and your warranty.

Do not install cables over horizontal surfaces where they may be stood on or hit by falling objects.

**Failure to adhere to these warnings and cautions may lead to death, serious injury or property damage. Trimble Inc disclaims all liability for installation or use of the LOADRITE Weighing System that causes or contributes to death, injury or property damage, or that violates any law.**

# Table of Contents

<b>1.0 Welcome</b>	<b>10</b>
<b>2.0 Introduction</b>	<b>11</b>
2.1 LOADRITE equipped loader	12
2.2 Indicator features	13
2.3 Accurate weighing	15
2.3.1 Obtaining the Best Weighing Results	15
2.3.2 Legal for Trade Systems	15
<b>3.0 The day-to-day weighing process</b>	<b>16</b>
3.1 How do I turn on the Indicator?	16
3.2 How do I log in?	16
3.3 How do I perform a warm-up?	17
3.4 How do I zero the empty bucket?	17
3.5 How do I select a product to weigh?	19
3.6 How do I weigh and add a bucketload?	19
3.6.1 What is Auto-Add?	20
3.6.2 Remote Add button	21
3.6.3 Subtract a bucketload	21
3.6.4 Recall a bucketload	22
3.7 How do I enter a reason for a delay?	24
3.8 How do I finish the load?	24
3.9 How do I put the Indicator into Standby mode?	25
<b>4.0 The Total screen</b>	<b>26</b>
4.1 Classic layout	27
4.2 Compact layout	28
4.3 Scroll layout	29
4.4 The short and long totals	30
4.4.1 Clear the short total	30
4.4.2 View and clear the long total	30
<b>5.0 Product Management</b>	<b>32</b>
5.1 Customizable Data fields	32
5.1.1 Select a data field	32
5.1.2 Adding a data field value	33
5.1.3 Editing a data field value	33
5.1.4 Docket numbers	34
5.1.5 Data Suspend	35
5.2 Advanced Data Options	36
5.2.1 Auto-target value look-up	36
5.2.2 Auto-tare value look-up	37
5.2.3 Prompt	37

<b>6.0 Operation Modes</b>	<b>38</b>
6.1 Target Weighing mode	39
6.1.1 How do I enter Target Weighing mode and input a target?	39
6.1.2 How do I reset the target?	40
6.1.3 How do I return to Total mode?	40
6.2 Batch Mode	41
6.2.1 How do I enter Batch mode and select a recipe for the batch?	41
6.2.2 How do I delete the current recipe?	42
6.2.3 How do I enter a new recipe?	42
6.2.4 How do I switch between products?	43
6.2.5 How do I clear the batch totals?	43
6.2.6 How do I return to Total mode?	43
6.3 Mix mode	44
6.3.1 How do I enter Mix mode and select a recipe for the batch?	44
6.3.2 How do I delete the current recipe?	45
6.3.3 How do I enter a new recipe?	45
6.3.4 How do I switch between products?	46
6.3.5 How do I clear the totals?	46
6.3.6 How do I return to Total mode?	46
6.4 Blend mode	47
6.4.1 How do I enter Blend mode and select a recipe for the batch?	47
6.4.2 How do I delete the current recipe?	48
6.4.3 How do I enter a new recipe?	48
6.4.4 How do I switch between products?	49
6.4.5 How do I clear the totals?	49
6.4.6 How do I return to Total mode?	49
6.5 Split Weighing mode	50
6.5.1 Using Split Weighing mode within Total mode	50
6.5.2 Using Split Weighing mode within Target Weighing mode	51
6.6 Grand Total mode	52
<b>7.0 Advanced Weighing – Tip-Off</b>	<b>53</b>
7.1 Truck tip-off	53
7.2 Stock pile tip-off	54
<b>8.0 Advanced Weighing - Tare Weight</b>	<b>55</b>
8.1 How do I enter a tare weight?	55
<b>9.0 Delay Entry</b>	<b>56</b>
<b>10.0 Metrics</b>	<b>57</b>
10.1 Viewing your metrics for today	57
10.2 Comparing your metrics	58
<b>11.0 Printing</b>	<b>59</b>
11.1 Automatic printing	59

11.2	Printing on demand .....	59
11.2.1	Print Docket .....	59
11.2.2	Print Totals .....	59
11.2.3	Print Indicator Data .....	60
11.2.4	Print LOADRITE Data Module Data .....	60
11.2.5	Print Special Report .....	60
11.2.6	Print Summary Report .....	62
11.2.7	Print Data List .....	62
11.2.8	Set Number of Copies .....	62
11.2.9	Print Product Names .....	62
11.2.10	Print Volume Conversion Factors .....	62
11.2.11	Print Standby Message .....	63
<b>12.0</b>	<b>Internal Storage .....</b>	<b>64</b>
12.1	Reset .....	64
<b>13.0</b>	<b>Setup Menu .....</b>	<b>65</b>
13.1	Setup... .....	66
13.2	Auto-Add .....	66
13.3	Tare Entry .....	66
13.4	Unit Toggle .....	66
13.5	Trig Screen .....	67
13.6	Language .....	67
13.7	Edit Password .....	67
13.8	Scale # .....	67
13.9	Module .....	67
13.10	Data Edit .....	68
13.11	Data List .....	68
13.11.1	Adding a data value .....	68
13.11.2	Editing a data field value .....	69
13.12	Clock .....	70
13.12.1	Setting the time .....	70
13.12.2	Setting the date .....	71
13.12.3	Setting the year .....	71
13.12.4	Alarm .....	71
13.12.5	Alarm time .....	71
13.13	Display .....	72
13.13.1	Changing the screen brightness .....	72
13.13.2	Changing the screen contrast .....	72
13.13.3	Selecting Arm Graphic .....	72
13.13.4	Changing the Total screen layout .....	73
13.13.5	Changing the Target screen layout .....	73
13.14	Long total .....	73
13.15	Clear all .....	73
13.16	Self test .....	73
13.17	Uplink .....	74
13.17.1	Uploading a configuration file via a EDP cable .....	74

13.17.2 Uploading a configuration file via a LOADRITE Data Module .....	74
13.18 Standby .....	74
<b>14.0 Appendix A: System Specifications .....</b>	<b>75</b>
14.1 Weighing accuracy .....	76
14.2 Minimal weighing delay .....	76
14.3 Power requirements .....	76
14.4 Physical specifications .....	76
14.5 Environmental specifications .....	77
14.6 Signal inputs and outputs .....	77
14.7 Clock .....	77
14.8 Output / Input connections .....	77
14.8.1 Power / Control .....	78
14.8.2 Printer / Data Logger .....	78
14.8.3 Pressure Transducer .....	78
<b>15.0 Appendix B: Span Calibration Adjustment .....</b>	<b>79</b>
15.1 Checking the adjustment .....	80
<b>16.0 Appendix C: Error Messages .....</b>	<b>81</b>
16.1 Bouncing load .....	81
16.2 Bucket back? .....	81
16.3 Bucket empty? .....	81
16.4 Bucket not back .....	81
16.5 Calibration Reminder .....	82
16.6 Check power .....	82
16.7 Check MAG/OPT .....	82
16.8 Check rotary .....	82
16.9 Check scale# .....	82
16.10 Check tilt .....	82
16.11 Check transducer .....	82
16.12 Check zero .....	82
16.13 Lift under range .....	83
16.14 Low battery .....	83
16.15 Need emptying .....	83
16.16 No lock .....	83
16.17 Num Attempts Exceeded .....	83
16.18 Over target .....	83
16.19 Overload .....	83
16.20 Pitch too high .....	84
16.21 Poor lift .....	84
16.22 Printer disabled .....	84
16.23 Printer error .....	84
16.24 Return under range .....	84
16.25 Roll too high .....	84
16.26 Speed changed .....	84



16.27	Speed too high	85
16.28	Tilt too high	85
16.29	Too heavy, zero aborted	85
16.30	Warm-up lift	85

**17.0 Appendix D: Legal Information** .....86

# 1.0 Welcome

Thank-you for purchasing this LOADRITE Weighing System. Please read this manual carefully before using the Indicator for the first time. Keep this manual in a safe place and use as your first point of reference.

## Formatting

The following formatting in this manual identifies specific types of information:

Convention	Type of Information
<b>Bold</b>	<ul style="list-style-type: none"> <li>■ Indicates a button on the Indicator, or</li> <li>■ Indicates an area displayed on-screen, including buttons, headings, field names and options.</li> </ul>
<i>Italics</i>	<ul style="list-style-type: none"> <li>■ Indicates the name of a screen or window, or</li> <li>■ Indicates an operation mode that the Indicator can be set to.</li> </ul>
Monospace	The exact error message displayed on-screen.

## Action Terms

The following terms are used throughout this manual to describe actions:

Term	Description
<b>Press</b>	Push and release a button quickly.
<b>Press and hold</b>	Push and hold a button for 2-3 seconds.
<b>Select</b>	<ul style="list-style-type: none"> <li>■ Use the arrow buttons to "highlight" an item in a menu or list, or</li> <li>■ When searching for a product or Data Field value, use the keypad to enter the name of the product. The product which matches the name entered will be "highlighted".</li> </ul>

## 2.0 Introduction

The LOADRITE weighing system measures the weight of loads lifted by wheel loaders, forklift trucks and similar machines that use hydraulic rams to lift the load. The main parts of the LOADRITE Weighing System are:

- the Indicator installed in the cab of the loader, and
- the connected sensors installed on the lifting arms.

As a load is lifted, the trigger and hydraulic pressure transducers send information to the LOADRITE Indicator. This information is converted into a digital weight reading that is displayed on the LOADRITE Indicator.

The *LOADRITE Payload Management for Earthworks* system can add each lifted load to running totals so that trucks are loaded accurately and daily productivity levels can be tracked.

The LOADRITE Indicator is the main user interface with the LOADRITE Weighing System. It has an internal memory that stores settings and production data even when it is turned off.





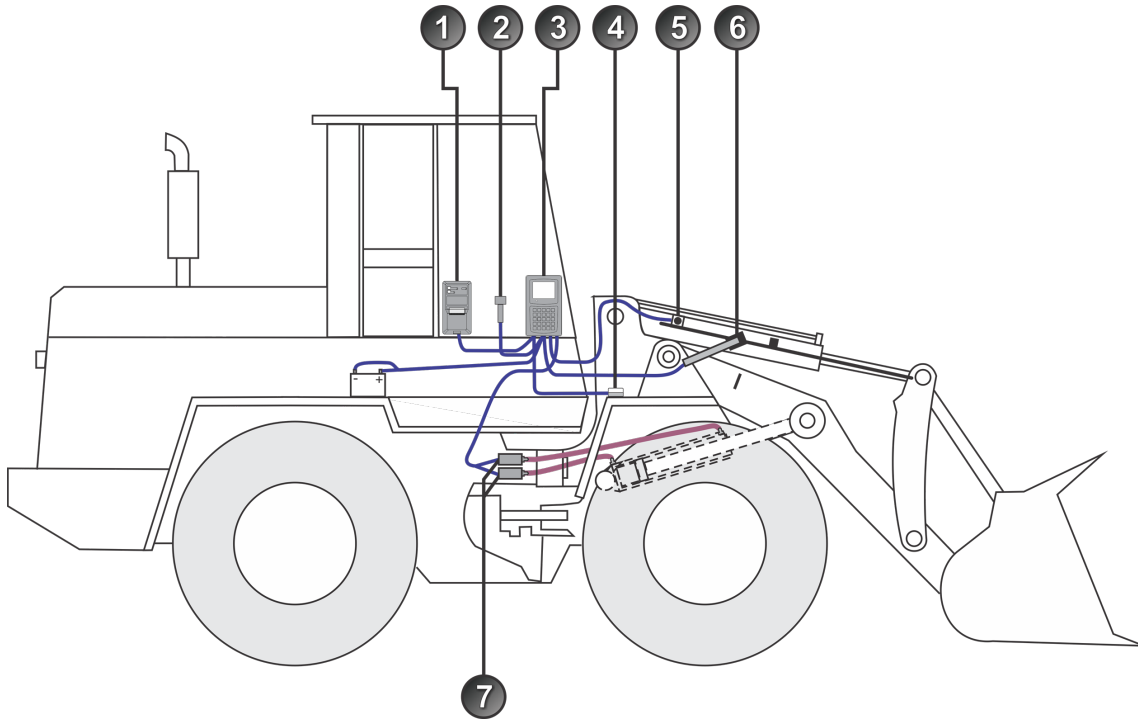



















## 2.1 LOADRITE equipped loader



Item	Description
1	Printer (optional)
2	Remote Add Button
3	LOADRITE Indicator
4	Ground Slope Sensor (optional)
5	Interlock Switch (optional; required for Legal for Trade application)
6	Trigger
7	Pressure Transducer

## 2.2 Indicator features

Icon	Name	Description
	<b>Trigger Light</b>	Illuminates when a load is lifted past the Trigger Point. When this light is on, the load may be added.
	<b>Data Menu</b>	Displays the <i>Data Menu</i> .
	<b>Target</b>	Activates <i>Target</i> mode weighing.
	<b>Split</b>	Activates <i>Split</i> mode weighing.
	<b>Tip-Off Decimal Point</b>	<ul style="list-style-type: none"> <li>■ Activates Tip-off weighing.</li> <li>■ Used to enter a decimal point.</li> </ul>
	<b>Setup Menu Standby Mode</b>	<ul style="list-style-type: none"> <li>■ Accesses the <i>Setup Menu</i>.</li> <li>■ Press and hold for five seconds to enter <i>Standby</i> mode.</li> </ul>
	<b>Up</b>	Moves down a list of options.
	<b>Down</b>	Moves down a list of options.
	<b>Enter</b>	<ul style="list-style-type: none"> <li>■ Selects an item.</li> <li>■ Accepts changes.</li> </ul>
	<b>One</b>	Used to enter the number <b>1</b> .
	<b>Two</b>	Used to enter the number <b>2</b> .
	<b>Three</b>	Used to enter the number <b>3</b> .
	<b>Four</b>	Used to enter the number <b>4</b> .
	<b>Five</b>	Used to enter the number <b>5</b> .

Icon	Name	Description
	<b>Six</b>	Used to enter the number <b>6</b> .
	<b>Seven</b>	Used to enter the number <b>7</b> .
	<b>Eight</b>	Used to enter the number <b>8</b> .
	<b>Nine</b>	Used to enter the number <b>9</b> .
	<b>Recall Subtract Back</b>	<ul style="list-style-type: none"> <li>■ Recalls the last load.</li> <li>■ Subtracts the current load from the total.</li> <li>■ Moves back one menu screen.</li> </ul>
	<b>Zero</b>	Used to enter the number <b>0</b> .
	<b>Add</b>	<ul style="list-style-type: none"> <li>■ Adds the current bucket load to the total.</li> <li>■ Turn <i>Auto-Add</i> on or off.</li> </ul>
	<b>Clear</b>	Clears the short total for the current product.
	<b>Zero Bucket</b>	Zeroes the empty bucket.

## 2.3 Accurate weighing

For maximum accuracy, ensure that:

- Check Zero is performed regularly.
- Load lifting motion is steady and smooth, with no acceleration or bounce.
- The bucket is fully rolled back during the lift.
- The loader is on level ground.

**TIP** – If the *Ground Slope Compensation* sensor is installed, the loader does not have to be level when lifting.

### 2.3.1 Obtaining the Best Weighing Results

#### Lifting speed

For best results, operate the lift lever before accelerating the engine so that the machine does not rock as it lifts, i.e. use normal revs.

#### Trigger Point

Start the lift well below the Trigger Point. This ensures that all acceleration and load bounce has been eliminated well before the weighing sequence begins.

**NOTE** – We recommend that there are at least two seconds of lift before passing the Trigger Point.

#### Bounce

Most loaders have pneumatic tires which can cause the machine to bounce when lifting.

To minimize the effect of bounce, always operate the lift lever before accelerating the engine and start the lift well below the Trigger Point.

#### Center of gravity

The hydraulic pressure in the lifting cylinders depends on where the center of gravity of the load is. It is important that the bucket is always in the same position: fully rolled back.

### 2.3.2 Legal for Trade Systems

LOADRITE systems meet Legal for Trade requirements in certain countries. This enables material to be weighed and sold directly from the loader.

For more information or to enquire if Legal for Trade is available in your country, contact your LOADRITE distributor.



**TIP** – Operating requirements for Legal for Trade systems are detailed in this manual where they differ from standard operating requirements.

## 3.0 The day-to-day weighing process

The following is the basic process for day-to-day weighing with the LOADRITE Weighing System:

1. Turn on the Indicator and login (if required).
2. Perform the required warm-up lifts.
3. Zero the empty bucket.
4. Select a product to weigh (optional).
5. Weigh and add each bucketload.
6. When you have finished loading the truck, clear the short total.
7. When you have finished using the LOADRITE Weighing System, put the Indicator into *Standby* mode.

### 3.1 How do I turn on the Indicator?

The LOADRITE Indicator will turn on automatically when you start the loader.



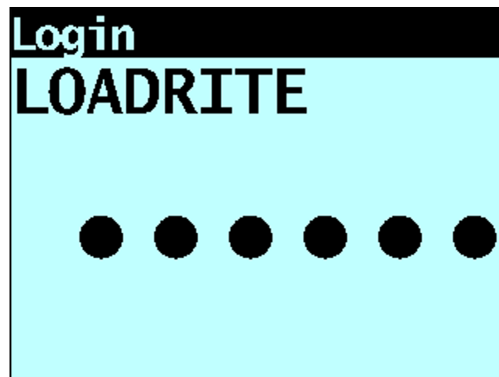

### 3.2 How do I log in?

**The *Login* functionality is only available if selected at installation.**

The *Login* screen will display when the Indicator is turned on, or comes out of *Standby* mode.



If you see the *Login* screen, complete the following to log in to the Indicator:

1. Press  or  to scroll up or down through the login names, or use the keypad to enter your login name.
2. When your login name is displayed, press .
3. Use the keypad to enter your PIN number, then press .



### 3.3 How do I perform a warm-up?

For best weighing accuracy, the hydraulic fluid in the lift cylinders should be at normal operating temperature. This is achieved by raising and lowering the empty bucket.

#### Warm Up Lift 3

The above message will display if the Indicator has been turned off for more than one hour. If you see the above message, you need to raise and then lower the empty bucket past the Trigger Point three times:

1. Raise the bucket past the Trigger Point.
2. Lower the bucket past the Trigger Point.
3. Repeat two more times until the message disappears.  
When the warm-up has completed, the *Total* screen will display.

### 3.4 How do I zero the empty bucket?

The **Check Zero** functionality is only available if selected at installation.

It is necessary to periodically "zero" the bucket because small errors can occur due to a build-up of material in the bucket. The Friction and Ambient Compensation Technology (FACT) functionality is also updated as part of the zeroing process.



#### Check Zero

If you see the above message, you need to zero the empty bucket. The message will display:

- Every 15 minutes for the first hour, and
- Every 30 minutes thereafter (the default period is 30 minutes, but it may be set between 15-180 minutes).

**IMPORTANT** – When zeroing the Indicator, the bucket must be empty and kept fully-rolled back.

Complete the following to zero the bucket:

1. Raise the empty bucket.
2. Press .  
The **Zero Updated** message will display, before the *Total* screen is displayed.
3. Ensure that the loader is level and the bucket is empty.
4. Raise the empty bucket.
5. Press  .  
The lifting speed will display.





**NOTE** – If during installation the FACT update was set to be skipped, press  again to continue. The update may only be skipped a set number of times before an update must be completed.

6. When the **Lower Arms** message is displayed, lower the empty bucket. The lowering speed will display.

**NOTE** – The same speed must be maintained for lifting and lowering. If the difference between speeds is too large, the Indicator will prompt you to try again.

The **Zero Updated** message will display, before the *Total* screen is displayed.

## 3.5 How do I select a product to weigh?



1. Ensure that the *Total* screen is displayed.
2. Press .  
The *Data Menu* will display.
3. Select **Product**, then press .  
The *Product* screen will display.
4. Press  or  to scroll up or down the list of products, then press .  
The name of the Product will be displayed for one second, then the *Total* will display.

## 3.6 How do I weigh and add a bucketload?

When the *Total* screen is displayed, bucketloads can be weighed.

**NOTE –** When weighing a bucketload, the bucket must be kept fully-rolled back.

1. Raise the bucketload smoothly through the Trigger Point using constant engine revs.  
The **Weighing** message will display.
2. When the bucketload has been weighed, the Indicator will beep, the  (Trigger light) will illuminate, and the *Live Weight* screen will display the following:
  - the current bucketload weight,
  - the weight of the short total,
  - the new short total if the bucketload is added.

PROD01	
	3.240
	12.500
<hr/>	
15.740	
12:19PM	 1A+ tonne

- Press  to add the bucketload to the short total.  
A message will display the number of buckets added to the current load, for example **Bucket added. Add #1.**

**NOTE** – If  is not pressed within 8 (eight) seconds of the load being lifted past the Trigger Point, the Indicator will beep and the **Weight Discarded** message will display. The weight will then be discarded and the *Total* screen will display.

When the load has been added, the *Total* screen will display with the new short total and the number of added bucketloads.

- Empty the bucketload in to the truck.

### 3.6.1 What is Auto-Add?





The *Auto-Add* functionality is only available if enabled at installation.



The *LOADRITE Payload Management for Earthworks* system can be set to automatically add a bucketload when lifted past the Trigger Point for a specified number of seconds *OR* when the bucket is rotated forward to tip off the load. This means that you don't need to press  after lifting each load.

The following may apply depending on how *Auto-Add* functionality was configured at installation:

- Bucket loads may not be added if under a specified amount
- *Auto-Add* may be turned on or off via the *Setup Menu* or by pressing  (Auto-Add toggle).

#### 3.6.1.1 Turn Auto-Add On or Off

- Press .  
The *Setup Menu* will display.
- Press  or  to scroll up or down until **Auto-Add** is selected, then press .
- Complete the following:

If you want to...	Then...
turn <i>Auto-Add</i> on	use the arrow buttons to select <b>On</b> , then press  .
turn <i>Auto-Add</i> off	use the arrow buttons to select <b>Off</b> , then press  .



- Press  to return to the *Total* screen.

### 3.6.1.2 Auto-Add toggle



The *Auto-Add toggle* functionality may or may not be available, depending the configuration of your Indicator.

You can toggle between using Auto-add and using the normal add process from the *Total* screen.

#### Turn Auto-Add on

1. From the *Total* screen, press .  
The **Auto-Add On?** message will display.
2. Press .  
The message will change to **Auto-Add On** and the *Total* screen will display.

#### Turn Auto-Add off

1. From the *Total* screen, press .  
The **Auto-Add Off?** message will display.
2. Press .  
The message will change to **Auto-Add Off** and the *Total* screen will display.

### 3.6.2 Remote Add button

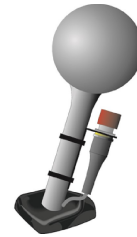

The LOADRITE Weighing System has an optional **Remote Add** button which is normally mounted on or near the lift lever. If the **Remote Add** button is installed in your loader you can use it interchangeably with the  button on the Indicator.



### 3.6.3 Subtract a bucketload

This function can be useful when only part of a final load of loose material is required. Weigh and add a full bucketload, but only tip the amount required into the truck. Then re-weigh and subtract the amount remaining by completing the following:

**NOTE** – When weighing a bucketload, the loader must be level with the bucket kept fully-rolled back.

1. Raise the bucketload smoothly past the Trigger Point.
2. The Indicator will beep,  (**Trigger light**) will illuminate and the weight of the current load, the short total and the potential new weight will display.
3. Press .  
The **Bucket Subtract** message will display. The amount will be subtracted from the short total. The *Total* screen will display.

### 3.6.4 Recall a bucketload

The *Recall* function is equivalent to lifting the same load again and can be used to correct mistakes. The last bucketload can be recalled if it has been added, subtracted or cancelled.



To recall a previously lifted weight, complete the following:

1. Press .

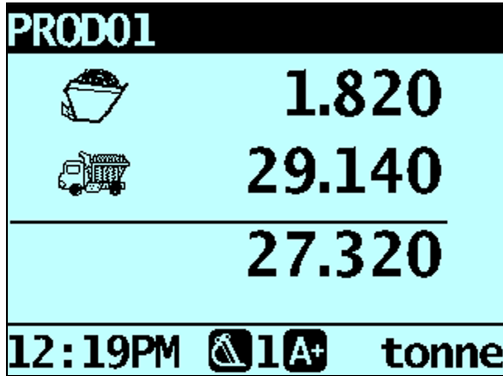
The last valid weight that was lifted will be displayed.



2. Complete the following:











If...	Then...
the last action was an "add"	press  . The bucketload is subtracted from the short total and long total.
the last action was a "subtract"	press  . The bucketload is added to the short total and long total.



## How do I use the keypad to enter text?



You can enter numbers, letters or symbols on any screen that has a flashing cursor, for example the *Data Entry* and *Edit?* screens. The Indicator has a keypad of buttons, with each used to select and enter a range of characters. When a button is pressed, the first character will appear on screen. If you press the button again within one second, the next character will display. If you continue to press the button, each character in the range will display in turn until the first character is displayed again. One second after a button is pressed, the character will be entered and the cursor will move to the next space. You can then enter another character.

**TIP** – Predictive text is available on some screens, if it has been enabled during installation. This means that you may only need to enter the first few characters of a word for the whole word to display on screen.

### Characters







Button	Characters	Button	Characters
	[SPACE] 1 . , ? &		6 M N O m n o
	2 A B C a b c		7 P Q R S p q r s
	3 D E F d e f		8 T U V t u v
	4 G H I g h i		9 W X Y Z w x y z
	5 J K L j k l		[SPACE] 0 # : / + - "

When entering the first character of a value, the first time  is pressed, the number **2** will display; the second time  is pressed, **A** will display; the third time  is pressed, **B** will display, etc.

When entering other characters in the value, lower-case letters will display first, so the first time  is pressed, the letter **a** will display; the second time  is pressed, **b** will display; the third time  is pressed, **c** will display, etc.

### Example

To enter the word **Pumice** using the keypad, you would complete the following:

- To enter **P**, press  twice.
- To enter **u**, press  twice.
- To enter **m**, press .
- To enter **i**, press  three times.
- To enter **c**, press  three times.
- To enter **e**, press  twice.

## 3.7 How do I enter a reason for a delay?

*Delay Reason Entry* functionality is only available if enabled during installation.

The LOADRITE Indicator will automatically detect if there has been a delay to weighing and display the *Delay Entry* screen so that you can select the reason for the delay. You can also manually enter a reason via the *Print Menu* if you know that there is going to be a delay to weighing.

The reasons for these delays are recorded and can be used to generate a report using LOADRITE InsightHQ.

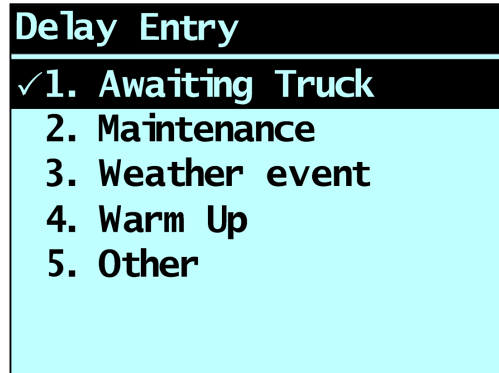

If you see the *Delay Entry* screen, you need to enter a reason for the delay by completing the following:

- Either use to to select the reason for the delay, OR
- press or to scroll through the delay reasons, then press to select the reason.

**NOTE** – If a reason is not selected within 10 seconds, the **Other** option will be automatically selected.

The delay will be set and the **Delay** message will display at the top of the screen until the next bucketload is added.

## 3.8 How do I finish the load?

When you have finished adding bucketloads to the truck, you must clear the short total.

To clear the short total, complete the following:

- Press and hold .
- The short total will display briefly, followed by the **Total Cleared** message, then the *Total* screen. If a printer is connected to the LOADRITE Weighing System, a docket of the loader's totals will be printed.

For more information on the short total, see "*The short and long totals*" on page 30.







## 3.9 How do I put the Indicator into *Standby* mode?

If you are not going to use the LOADRITE Weighing System for a while, you can put the Indicator into *Standby* mode by completing the following:

### Option 1

- Press and hold  for 5 seconds.  
The Indicator will enter *Standby* mode.

### Option 2

1. Press .
  2. Press  or  to scroll up or down until **Standby** is selected, then press .
- The Indicator will enter *Standby* mode.

### Option 3

The LOADRITE Indicator will automatically go into *Standby* mode if it is not used for two hours.

### How do I exit *Standby* mode?

- Press any button to exit *Standby* mode.  
Either the *Login* screen or *Total* screen will display.

# 4.0 The Total screen

The *Total* screen is the first screen that you will see when you turn on the Indicator or log in. The *Total* screen can be displayed in three layouts:

- Classic layout
- Compact layout
- Scroll layout

To change the layout of the *Total* screen, see "*Changing the Total screen layout*" on page 73.

## 4.1 Classic layout

The *Classic* layout of the *Total* screen is the default layout and displays the currently selected Product, short total, number of bucket loads and other information.

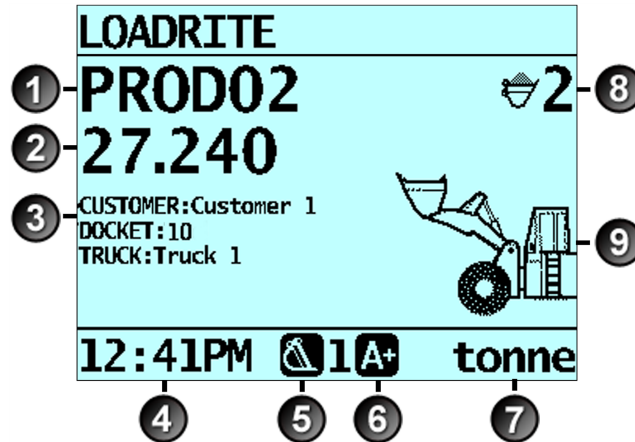





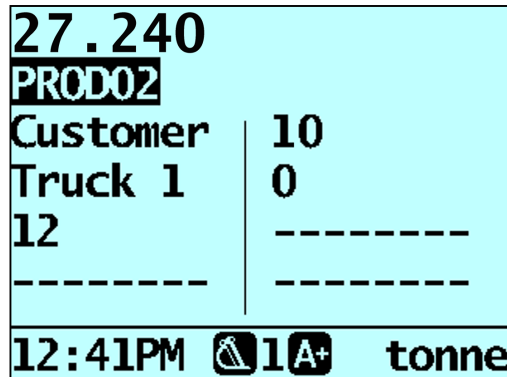

	Component	Description
1	Product	The product being loaded.
2	Short total	The current short total of material that has been loaded.
3	Data Fields	The current values of each Customizable Data Field. <div style="border: 1px solid green; padding: 5px; margin-top: 10px;"><b>TIP</b> – To display the current values of <i>all</i> data fields, use either the <i>Compact</i> or <i>Scroll</i> layout.</div>
4	Clock	The current time.
5	Weighing implement	The weighing implement being used by the loader.
6	Auto-add	Indicates that the <i>Auto-add</i> functionality is <b>On</b> .
7	Unit of weight / Pitch	<ul style="list-style-type: none"> <li>■ The unit of weight being used. The <b>Short total</b> is displayed in this unit of weight.</li> <li>■ The angle of pitch (front/back tilt) of the loader may be displayed if a Ground Slope sensor is installed.</li> </ul>
8	Bucket loads	The number of bucketloads that have been added to the short total.
9	Arm Graphic	A graphic representing the height of the lifted weight.

## 4.2 Compact layout

The *Compact* layout of the *Total* screen displays the short total, currently selected product and all eight customizable Data Fields (if selected).



How do I change the product or one of the Data Field values?

1. Press  or  to select the product or Data Field that you want to change, then press . The *Product* screen or the applicable *Data Field* screen will display.
2. Press  or  to select the product or Data Field value that you want to use, then press . The *Total* screen will display with the new product or Data Field value displayed.





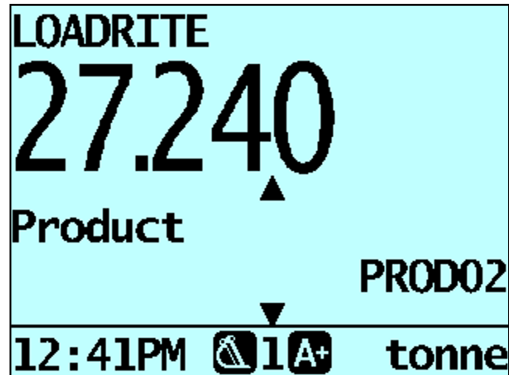

## 4.3 Scroll layout

The *Scroll* layout of the *Total* screen displays the short total in a large easy-to-read font size and one of the eight Data Fields.

- To scroll through the Data Fields, press  or .



How do I change the product or one of the Data Field values?

1. Press  or  to select the product or Data Field that you want to change, then press . The *Product* screen or the applicable *Data Field* screen will display.
2. Press  or  to select the product or Data Field value that you want to use, then press . The *Total* screen will display with the new product or Data Field value displayed.

## 4.4 The short and long totals

The LOADRITE Weighing System keeps a running total of the load weights. For each product, two independent totals are stored - the short total and the long total.

Term	Definition
<b>Short Total</b>	The running total amount of product weighed and loaded onto a truck or carriage. The Short Total amount is displayed on the <i>Total</i> screen and will continue to accumulate until it is cleared by pressing  .
<b>Long Total</b>	The total amount of product loaded over a long period, such as a work shift or day.

### 4.4.1 Clear the short total

The short total keeps accumulating until it is cleared. Clear the short total after a load has been completed, for example, after each truck or carriage load.





- Press .

The short total will display briefly, followed by the **Total Cleared** message, then the *Total* screen.

**NOTE** – If the LOADRITE Weighing System has a printer connected, then depending on your installation settings, (i) the totals may be printed before being cleared, or (ii) you may be prompted to print the totals after the **Total Cleared** message is displayed.

### 4.4.2 View and clear the long total

You can view the long total for the current product at any time:







1. Ensure the *Total* screen is displayed, then press .
2. Press  or  to scroll up or down until **Long Total** is selected.
3. Press .

The long total will display, followed by the number of buckets added.

Long Total  
24.540 tonne







After a few seconds, the Indicator will display the *Total* screen.

## Clear the long total for the current product

1. Ensure the *Total* screen is displayed, then press .
2. Press  or  to scroll up or down until **Long Total** is selected.
3. Press .  
The long total for the current product is displayed.
4. Press .  
The **Long Total Clear?** message will display.
5. Press  again to clear the long total.  
The **Long Total Cleared** message will display. If the LOADRITE Weighing System has a printer connected, the total will be printed.
  - Press  to cancel the clearing of the long total.  
The **Clear Aborted** message will display.

**NOTE** – If no button is pressed, the clear command will be automatically canceled.

## Clear the long total for all products

1. Ensure the *Total* screen is displayed, then press .
2. Press  or  to scroll up or down until **ClearAll** is selected.
3. Press .  
The **All Totals Clear?** message will display.
4. Press  again to clear the long total.  
The **All Totals Cleared** message will display. If the LOADRITE Weighing System has a printer connected, the total will be printed.
  - Press  to cancel the clearing of the long total.  
The **Clear Aborted** message will display.

**NOTE** – If no button is pressed, the clear command will be automatically canceled.

# 5.0 Product Management

The LOADRITE Weighing System can be used to track multiple products. Each product is associated with a product number, product name, Short Total, Long Total and bucket counter.

## 5.1 Customizable Data fields

**The *Customizable Data Fields* functionality is only available if selected at installation. For information on configuring data fields, refer to the *LOADRITE InsightHQ Configuration Manual*.**

Your Indicator has eight customizable data fields that are used to record information against each weight to help track and monitor weighing data. For example, data fields may be configured to record a customer, truck type/truck ID or docket number, against the weight data. The data can then be transferred to InsightHQ via a Wi-Fi network, stored in a LOADRITE Data Module and/or printed along with the weight data.



### 5.1.1 Select a data field

Data field values can be selected before starting a new load. The following example assumes that **Data 1** has been configured to hold customer names and shows how to select a customer name to record against the weighing data.

1. Press .  
The *Data Menu* will display.

2. Select **Customer**, then press .  
The *Customer* screen will display.

CUSTOMER	1/33
Customer 1	
✓ Customer 2	
Customer 3	
Customer 4	
Customer 5	
Customer 6	

3. Press  or  to scroll up or down the list until the correct Customer is selected.

4. Press .  
The Customer will be recorded against all loads until a different Customer is selected. The selected Customer will display under the **Short Total** on the *Total* screen.

**TIP** – A *Control* report can be created for the selected data field value by pressing .  
For more information, see "*Print Special Report*" on page 60.







## 5.1.2 Adding a data field value

If the required data field value is not available to select, you can add the value using the keypad.

**NOTE** – Data field values can only be entered using specific *Western Latin* characters, such as in English.



The following example assumes that **Data 1** has been configured to hold customer names and shows how to add a new customer name:

1. Press .  
The *Data Menu* will display.
2. Select **Customer**, then press .  
The *Customer* screen will display.
3. Press .  
The *Data Entry* screen will display.
4. Use the keypad to enter the name of the value, then press .  
The new customer value will be assigned to the next load.

## 5.1.3 Editing a data field value

You can edit a data field value if required by using the *Data List* function.



**NOTE** – Data field values can only be entered using specific *Western Latin* characters, such as in English.



1. Press .  
The *Setup Menu* will display.
2. Select **Data List**, then press .  
The *Edit?* screen will display.





3. Complete the following:

If ...	Then ...
you would like to edit a data value from the data field that is displayed	press  .





If ...	Then ...
you would like to select a different data field	press  until the required data field is displayed, then press  .

4. Press  or  to scroll up or down the list of data values until the required data value is displayed, then press . The *Data Entry* screen will display.

5. Use the keypad to edit the data value, then press .

**TIP** – Press  to clear the current value name.

6. Complete the following:



If ...	Then ...
you would like to edit another data value	<ul style="list-style-type: none"> <li>Press  until the required data value is displayed, then press .</li> <li>Go back to step 4.</li> </ul>
you would like to select a different data field	<ul style="list-style-type: none"> <li>Press  until the required data field is displayed, then press .</li> <li>Go back to step 5.</li> </ul>
you have finished editing data values	Press  twice to return to the <i>Setup Menu</i> .



## 5.1.4 Docket numbers

If a Data field has been set as an *AutoInc* (auto-incremental) value during installation, it can be used as a docket number. The docket number will increment by 1 and be automatically assigned every time a new load is started. Auto-incremented docket numbers cannot be entered manually.

- To edit the first number used for auto-incremented docket numbers, see "*Editing a data field value*" on page 69.

If a Data field has been set as a *number*, it can be used as a manually-entered docket number for each load. Complete the following to manually enter a docket number:

- Press . The *Data Menu* will display.
- Select **Docket**, then press . The *Docket* screen will display.

3. Press .
4. Use the keypad to enter a docket number, then press .  
The new docket number will be assigned to the next load.

## 5.1.5 Data Suspend





**The *Data Suspend* functionality is only available if selected at installation.**

Data Suspend is a feature that allows you to temporarily suspend data values and set them to **0** (zero).

While data is suspended, the LOADRITE Weighing System will:

- Exclude all suspended data fields in printing
- Override all suspended data fields with **0** in data logging
- Display the **Data Suspend** message instead of the data title on the *Total* screen.

Complete the following to suspend or resume data:

1. Press .  
The *Data Menu* will display.
2. Select **Data Suspend**, then press .  
The *Data Suspend* screen will display.
3. To suspend data, select **On**, then press ; To resume data, select **Off**, then press .

## 5.2 Advanced Data Options

### 5.2.1 Auto-target value look-up

The LOADRITE Weighing System can be configured so that target weights are stored for each truck. The target weights are configured during the setup of the LOADRITE Weighing System.

Below is an example of a truck and target list. **Data 2** has been configured to store truck ID numbers and **Data 3** to store the corresponding target values.





Data 2: Truck	Data 3: Target
DT123	150
DT124	150
DT125	150
DT344	300
DT345	300

#### 5.2.1.1 View and select target weights

1. Press .  
The *Data Menu* will display.

2. Select **Truck**, then press .  
The *Truck* screen will display.

TRUCK	1/1
DT123	
DT124	
✓ DT125	
DT344	
DT345	



3. Press  or  to scroll up or down the list of trucks until the correct truck is selected
4. Press .  
The target weights will display with the auto-target weight pre-selected.
5. Press  to confirm the target weight, or press  to clear the target weight and enter a new target weight.  
The *Target* screen will display.

## 5.2.1.2 Using an index number to view a truck target value

The LOADRITE Weighing System can be configured so that an index number can be used to look up the target for a particular truck

Following is an example of an indexed truck and target list. **Data 4** has been configured as a target list with the index function enabled. The index numbers are used to identify each truck.

Index	Data 4: Target
1 (AAT053)	25.000
2 (ABT384)	16.000
3 (AUS994)	15.500
4 (YE9444)	22.500
5 (UK9900)	22.000

1. Press .  
The *Data Menu* will display.
2. Select **Target**, then press .  
The *Target* screen will display.
3. Use the keypad to enter the index number of the truck, then press .  
The target for the truck will be displayed, then the *Total* screen will be displayed.

## 5.2.2 Auto-tare value look-up

This function is similar to *Auto-target value look-up*, except that it handles tare values. It is possible to recall the tare value from memory by either entering a number or scrolling through a list of truck names. The procedures are the same as the *Auto-target value look-up* functionality.

## 5.2.3 Prompt

**The *Prompt* functionality is only available if selected at installation.**

This function will automatically prompt for data field entries when a new product is selected or the current short total is cleared.

# 6.0 Operation Modes

The operation modes that are available depend on the modes selected at installation.

The LOADRITEIndicator can be operated in different modes:

Mode	Description
<b>Total</b>	This is the normal mode of operation. As loads are added, the weights are added to the totals. The short total is displayed.
<b>Target</b>	In this mode, a target weight is entered into the Indicator before loading. As loads are added, the remaining value to reach the target is displayed.
<b>Batch</b>	<i>Batch</i> mode allows the weighing and loading of different products according to a predefined recipe that specifies the required proportions. The grand batch target is entered before loading. The LOADRITEIndicator will work out individual product weights needed.
<b>Blend</b>	<i>Blend</i> mode allows a fixed number of loads of different products, according to a predefined recipe
<b>Mix</b>	This mode is similar to <i>Batch</i> mode except that the grand target is not required. Load the first product to a certain amount and the LOADRITEIndicator will work out how much of the other products are required based on relative quantities in the predefined recipe.
<b>Split</b>	The mode used when loading a multiple train wagons or a truck with multiple trailers where individual totals are required for each individual vehicle. Can be used within <i>Total</i> or <i>Target</i> modes.
<b>Grand Total</b>	This mode creates one grand total using short totals for all products. This can be used to ensure that the total across all products does not exceed a specified weight.

## 6.1 Target Weighing mode



**Target Weighing mode is only available if enabled at installation.**

*Target Weighing* mode provides a simple way to load a truck to a predefined target weight using a series of bucketloads. It is typically used when loading a truck to its optimum payload.

Before loading, enter a target weight value. Each time a bucketload is added, the target value is reduced by that amount.

- For using *Target Weighing* with multiple vehicle units (such as truck and trailer), see "*Using Split Weighing mode within Target Weighing mode*" on page 51.

### 6.1.1 How do I enter *Target Weighing* mode and input a target?

1. Press  to clear the previous short total.
2. Press .
3. When the **Target?** message is displayed, use the keypad to enter the new target amount.
4. Press . The **Target Updated** message will display briefly, then the *Target* screen will be displayed.

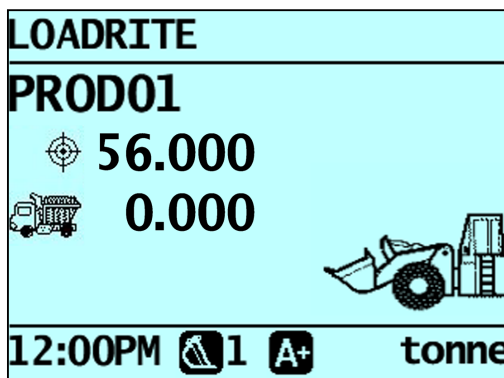

5. Raise a bucketload of product smoothly past the Trigger Point using constant engine revs. The message **Weighing** will display.

When the bucketload has been weighed, the Indicator will beep,  will illuminate, and the *Live Weight* screen will display the following:

- the target weight,
- the current bucketload,
- the new target weight, if the bucketload is added to the truck.

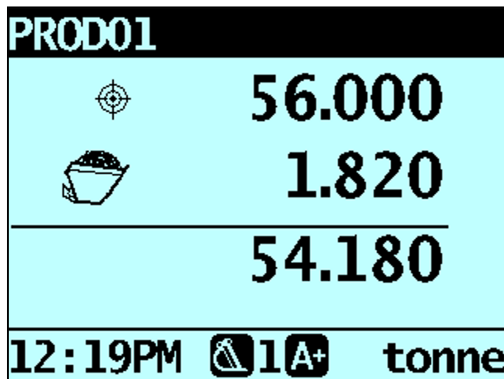

6. Press to add the bucketload to the truck.  
A message will display the number of buckets added to the current load, for example **Bucket Add #1**.
7. Empty the bucketload in to the truck.
8. Repeat steps 5-7 until the target weight value (bottom number) is as close as possible to the target weight value (top number).
9. Press to clear the target weight value.  
The *Total* screen will display.

## 6.1.2 How do I reset the target?

When the load is complete, the target must be reset. This is the equivalent of clearing the short total in *Total* mode.

- To reset the target, press .  
The **Target Reset** message will display briefly and then the *Target* screen will display.

## 6.1.3 How do I return to *Total* mode?

To return to *Total* mode from *Target Weighing* mode, the target must be set to **0** (zero).

1. Press .
  2. When the **Target?** message is displayed, press , then press .
- The *Total* screen will display.



## 6.2 Batch Mode

**Batch mode is only available if selected at installation.**

*Batch* mode allows products to be weighed and loaded according to a predefined *recipe*. Enter the target weight of the batch and your LOADRITE Weighing System will calculate the amount required for each product in the recipe. Each time a weight is added, the to load value is reduced by that weight.

A recipe can contain up to ten products and includes the relative amount of each product in a batch.

### Batch mode process

1. Enter *Batch* mode.
2. Select the current recipe or enter a new recipe for the batch.
3. Enter the total target amount for the batch.
4. Select a product and weigh each bucket-load until the product target is reached.
5. Repeat step 4 for each product in the recipe until the batch target is reached.

### Example: *Batch* mode calculation



A recipe of three products, their proportions and a total load of 7000kg. The LOADRITE Weighing System will calculate the amount of each product that is required for each load.

Product	Proportion	Amount Calculated
Sand	4	4000kg
Gravel	2	2000kg
Pumice	1	1000kg
	<b>Total</b>	7000kg

As products are loaded, the LOADRITE Weighing System maintains the target amount for each product in a similar way to *Target* mode. It is possible to change from one product to another at any time in order to mix the products.



When in *Batch* mode, the Indicator displays the target value for each product as it is weighed.

### 6.2.1 How do I enter Batch mode and select a recipe for the batch?

1. Press , then scroll if required until **Batch Mode?** is displayed.
2. Press .  
The **Batch Recipe** message will display.
3. Complete the following:



If...	Then...
the <b>Recipe Empty</b> message displays briefly, before displaying the	there is no recipe available. <ul style="list-style-type: none"> <li>■ To enter a new recipe, see "<i>How do I enter a new recipe?</i>" on page 48.</li> </ul>

If...	Then...
<i>Product</i> screen	
the <i>Recipe</i> screen displays	<p>there is a current recipe available.</p> <ul style="list-style-type: none"> <li>■ To accept the recipe, go to step 4.</li> <li>■ To enter a new recipe, see "How do I enter a new recipe?" on page 48.</li> </ul>

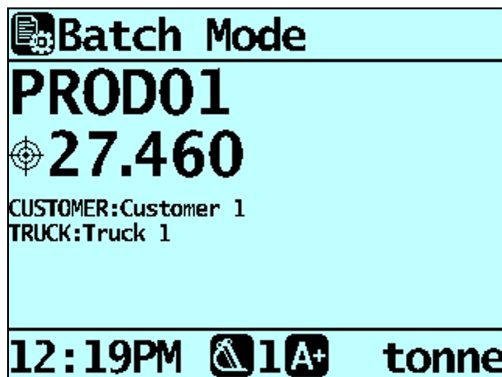
4. Press  (press again if prompted).  
The *Target?* screen will display.
5. When the **Target?** message is displayed, use the keypad to enter the total target amount for the batch.
6. Press .  
The *Batch* screen will display the target value for the first product from the recipe.



## 6.2.2 How do I delete the current recipe?





1. From the *Recipe* screen, press .  
The **Recipe: OK** message will display.
2. Press .  
The **Recipe Clear?** message will display.
3. Press  to delete the recipe.  
The **Recipe Empty** message displays briefly, before displaying the *Product* screen.

## 6.2.3 How do I enter a new recipe?

If there is no current recipe, or you have just deleted the current recipe, the *Product* screen will display.





**NOTE** – Before a new recipe can be entered, the current recipe must be deleted.

1. From the *Product* screen, press  or  to scroll up or down through the list to find a product required for the recipe.

2. Press  to select a product to add to the recipe.  
The *Target* screen will display.
3. Use the keypad to enter the required amount for the product, then press .  
The *Product* screen will display.
4. Repeat steps 1-3 until all of the required products and amounts have been added to the recipe.
5. When the recipe is complete, press .  
The **Recipe Updated** message will display before the *Recipe* screen is displayed.
6. Press  (press again if prompted).  
The *Total* screen will display.

## 6.2.4 How do I switch between products?

It is possible to load products in any order and switch between products at any time, as the LOADRITE Weighing System maintains the individual totals for each product.

1. Press .
2. The *Data Menu* will display. Select **Product**, then press .  
The *Product* screen will display.
3. Press  or  to scroll up or down to the required product, then press .  
The *Batch* screen will display the target value for the selected product from the recipe.

## 6.2.5 How do I clear the batch totals?

When the batch is complete, press .

The totals for all products are cleared, before the *Total* screen is displayed. This is the equivalent of clearing the total in *Total* mode.

## 6.2.6 How do I return to Total mode?

To return to *Total* mode from *Batch* mode, press .

You will also return to *Total* mode if you clear the batch totals or select a product which is not in the recipe.

## 6.3 Mix mode

**Mix mode is only available if selected at installation.**

Mix mode is similar to *Batch* mode except that a target value for the mix is not required.

Mix mode allows products to be weighed and loaded according to a predefined *recipe*. Load the first product to the required amount and your LOADRITE Weighing System will calculate the amount required for each of the remaining products based on the amount loaded for the first product.

The first product in the recipe is called the primary product. When the primary product is being loaded, the Indicator displays the short total for the recipe. When the other products in the recipe are selected, the Indicator displays the load value for the selected product.

A recipe can contain up to ten products.

### Mix mode process

1. Enter *Mix* mode.
2. Select the current recipe or enter a new recipe.
3. Select the first product and load it until the required amount is reached.
4. The LOADRITE Weighing System will calculate the target amount for each of the remaining products
5. Select the next product and weigh each bucket-load until the product target is reached.
6. Repeat step 5 for each product in the recipe until the target is reached.



### Example: *Mix* mode calculation

A recipe of three products and their proportions. When the primary product (sand for this example) has been loaded, the LOADRITE Weighing System will calculate the amount required for each of the other products in the recipe.

Product	Proportion	Amount
Sand (primary)	4	4000kg (loaded)
Gravel	2	2000kg (calculated)
Pumice	1	1000kg (calculated)

As products are loaded, the LOADRITE Weighing System maintains the target amount for each product in a similar way to *Target* mode. It is possible to change from one product to another at any time in order to mix the products.

### 6.3.1 How do I enter Mix mode and select a recipe for the batch?



1. Press , then scroll if required until **Mix Mode?** is displayed.
2. Press .  
The **Mix Recipe** message will display.

3. Complete the following:

If...	Then...
the <b>Recipe Empty</b> message displays briefly, before displaying the <i>Product</i> screen	there is no recipe available. <ul style="list-style-type: none"> <li>■ To enter a new recipe, see "<i>How do I enter a new recipe?</i>" on page 48.</li> </ul>
the <i>Recipe</i> screen displays	there is a current recipe available. <ul style="list-style-type: none"> <li>■ To accept the recipe, go to step 4.</li> <li>■ To enter a new recipe, see "<i>How do I enter a new recipe?</i>" on page 48.</li> </ul>

4. Press  (press again if prompted).  
The *Total* screen will display.







## 6.3.2 How do I delete the current recipe?

1. From the *Recipe* screen, press .  
The **Recipe: OK** message will display.
2. Press .  
The **Recipe Clear?** message will display.
3. Press  to delete the recipe.  
The **Recipe Empty** message displays briefly, before displaying the *Product* screen.

## 6.3.3 How do I enter a new recipe?





If there is no current recipe, or you have just deleted the current recipe, the *Product* screen will display.

**NOTE** – Before a new recipe can be entered, the current recipe must be deleted.

1. From the *Product* screen, press  or  to scroll up or down through the list to find a product required for the recipe.
2. Press  to select a product to add to the recipe.  
The *Target* screen will display.
3. Use the keypad to enter the required amount for the product, then press .  
The *Product* screen will display.
4. Repeat steps 1-3 until all of the required products and amounts have been added to the recipe.
5. When the recipe is complete, press .  
The **Recipe Updated** message will display before the *Recipe* screen is displayed.
6. Press  (press again if prompted).  
The *Total* screen will display.

## 6.3.4 How do I switch between products?

It is possible to load products in any order and switch between products at any time, as the LOADRITE Weighing System maintains the individual totals for each product.

1. Press .  
The *Data Menu* will display.
2. Select **Product**, then press .  
The *Product* screen will display.
3. Press  or  to scroll up or down to the required product, then press .  
The *Total* screen will display.

## 6.3.5 How do I clear the totals?

When all products have been loaded, press .  
The totals for all products are cleared, before the *Total* screen is displayed. This is the equivalent of clearing the total in *Total* mode.

## 6.3.6 How do I return to Total mode?

To return to *Total* mode, press .  
You will also return to *Total* mode if you clear the totals or select a product which is not in the recipe.

## 6.4 Blend mode

**Blend mode is only available if selected at installation.**

*Blend* mode is similar to *Batch* mode except that the recipe contains the total number of loads required for each product, rather than a target load.

When you load the first product, your LOADRITE Weighing System will automatically change to the next product when the required number of lifts has been reached.

A recipe can contain up to ten products.

### Blend mode process



1. Enter *Blend* mode.
2. Select the current recipe or enter a new recipe.
3. Select the first product and load it until the required number of lifts is reached.
4. The LOADRITE Weighing System will track the number of lifts and prompt you when to change products.
5. Select the next product and weigh each bucket-load until you are prompted to change products.
6. Repeat step 5 for each product in the recipe until all products have been loaded.

### Example: Blend mode calculation

A recipe of three products and the number of loads required. During weighing, the LOADRITE Weighing System will guide you through the process, resulting in 26 loads.

Product	Loads
Sand	6
Gravel	10
Pumice	10

### 6.4.1 How do I enter Blend mode and select a recipe for the batch?



1. Press , then scroll if required until **Blend Mode?** is displayed.
2. Press .  
The **Blend Recipe** message will display.
3. Complete the following:

If...	Then...
the <b>Recipe Empty</b> message displays briefly, before displaying the <i>Product</i> screen	there is no recipe available. <ul style="list-style-type: none"> <li>■ To enter a new recipe, see "<i>How do I enter a new recipe?</i>" on page 48.</li> </ul>
the <i>Recipe</i> screen displays	there is a current recipe available. <ul style="list-style-type: none"> <li>■ To accept the recipe, go to step 4.</li> </ul>

If...	Then...
	<ul style="list-style-type: none"> <li>To enter a new recipe, see "How do I enter a new recipe?" on page 48.</li> </ul>

4. Press  (press again if prompted).  
The *Total* screen will display.







## 6.4.2 How do I delete the current recipe?

- From the *Recipe* screen, press .  
The **Recipe: OK** message will display.
- Press .  
The **Recipe Clear?** message will display.
- Press  to delete the recipe.  
The **Recipe Empty** message displays briefly, before displaying the *Product* screen.

## 6.4.3 How do I enter a new recipe?

If there is no current recipe, or you have just deleted the current recipe, the *Product* screen will display.





**NOTE** – Before a new recipe can be entered, the current recipe must be deleted.

- From the *Product* screen, press  or  to scroll up or down through the list to find a product required for the recipe.
- Press  to select a product to add to the recipe.  
The *Target* screen will display.
- Use the keypad to enter the required amount for the product, then press .  
The *Product* screen will display.
- Repeat steps 1-3 until all of the required products and amounts have been added to the recipe.
- When the recipe is complete, press .  
The **Recipe Updated** message will display before the *Recipe* screen is displayed.
- Press  (press again if prompted).  
The *Total* screen will display.



## 6.4.4 How do I switch between products?

It is possible to load products in any order and switch between products at any time, as the LOADRITE Weighing System maintains the individual totals for each product.

1. Press .  
The *Data Menu* will display.
2. Select **Product**, then press .  
The *Product* screen will display.
3. Press  or  to scroll up or down to the required product, then press .  
The *Total* screen will display.

## 6.4.5 How do I clear the totals?

When all products have been loaded, press .  
The totals for all products are cleared, before the *Total* screen is displayed. This is the equivalent of clearing the total in *Total* mode.

## 6.4.6 How do I return to Total mode?

To return to *Total* mode, press .  
You will also return to *Total* mode if you clear the totals or select a product which is not in the recipe.

## 6.5 Split Weighing mode

**Split Weighing mode is only available if enabled at installation.**

*Split Weighing* mode splits the total weight into multiple sub-totals, providing an easy way to load train wagons, or a truck and trailer. *Split Weighing* mode is also used to track load distribution over a single vehicle unit, to avoid overloading an axle.

*Split Weighing* mode can be used in conjunction with *Total* or *Target Weighing* modes.

### Example

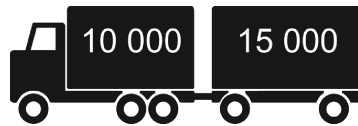



A truck with a trailer requires loading. The truck can carry 10,000 tonnes and the trailer 15,000 tonnes, making a total of 25,000 tonnes. First load the truck, then use *Split Weighing* mode to load the trailer.



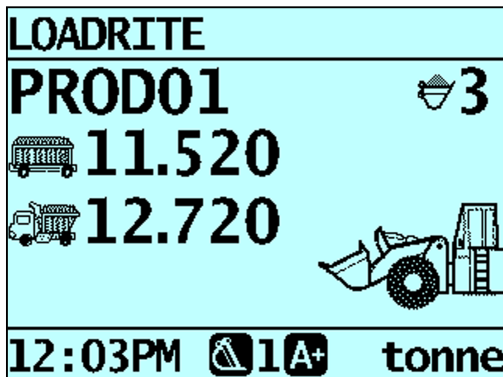

### 6.5.1 Using *Split Weighing* mode within *Total* mode

1. In *Total* mode, load the truck with the required amount or product.
2. When the required amount of product for the truck is reached, press . The subtotal will briefly display, then the *Split Mode* screen will display. The grand total of the entire vehicle is shown, along with the short total for the trailer.



3. Add the required amount of product to the trailer. As each bucketload is lifted, the bucket weight, current trailer weight and total trailer weight will display. Between each lift, the *Split Mode* screen will display showing the new total and number of buckets lifted.
4. If you would like to split the load to another trailer, press , then go to step 3. Otherwise, continue to step 5.
5. When all trailers have been filled, press  to clear the totals.

## 6.5.2 Using *Split Weighing* mode within *Target Weighing* mode

1. In *Total* mode, load the truck with the required amount or product.
2. When the required amount of product for the truck is reached, press . The subtotal will briefly display, then the *Split Mode* screen will display. The grand total of the entire vehicle is shown, along with the short total for the trailer.
3. Press .
4. When the **Target?** message is displayed, use the keypad to enter a target weight for the trailer. The *Split* screen will display showing the current target weight for the trailer and the grand total for the entire vehicle.
5. Raise a bucketload of product smoothly past the Trigger Point using constant engine revs. The message **Weighing** will display.
6. When the bucketload has been weighed, the Indicator will beep,  will illuminate and the *Live Weight* screen will display the following:
  - the target weight,
  - the current bucketload,
  - the new target weight, if the bucketload is added to the truck.
7. Press  to add the bucketload to the trailer. A message will display the number of buckets added to the current load, for example **Bucket Add #1**.
8. Empty the bucketload in to the trailer.
9. Repeat steps 3-9 until the target weight is as close to **0** (zero) as possible.
10. Repeat this procedure from step 2 for each additional trailer.

## 6.6 Grand Total mode

*Grand Total* mode is similar to *Split* mode in that it allows loading into a truck with multiple trailers, or a train with multiple wagons. Unlike *Split* mode however, different products can be loaded into each trailer or wagon.

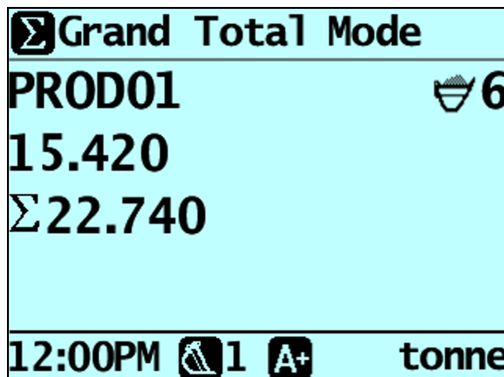

In *Grand Total* mode, a grand total is entered for the entire load. A short total is kept for all products which are added together to ensure that they do not exceed the grand total.

1. To enter *Grand Total* mode, press .  
The *Grand Total Mode* screen will display.

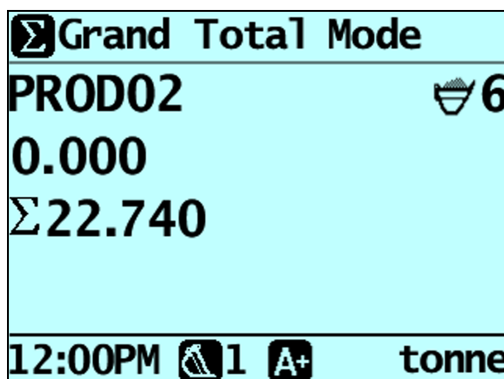

2. Load the truck with the required amount of product. The short total and the grand total will be updated.
3. When a new product is selected, the short total is reset to zero, but the grand total will be maintained for all products.



4. When all products have been loaded, press  to clear the totals.
5. To exit *Grand Total* mode, press , then press .

# 7.0 Advanced Weighing – Tip-Off

The *Tip-off* functionality is only available if selected at installation.

*Tip-off* weighing is the adjustment of the final load. It is possible to tip a measured amount of the product out of the last bucket to ensure an exact target weight is reached, where the final load would otherwise exceed the truck's capacity. There are two different methods, depending on the way your LOADRITE Weighing System has been configured:

- Truck tip-off (default)
- Stock pile tip-off

*Tip-off* is only available in *Total* and *Target* modes.

## 7.1 Truck tip-off

Using this method, the operator tips a measured amount of product from the bucket into the truck and dumps the rest.

1. Lift the load in the normal way.

The Indicator will display the lifted weight.

2. Lift the bucket to a suitable height over the truck, then press .

The **Tip-Off Wait** message will display briefly. Then the screen will display two figures, the amount in the bucket and the short total.

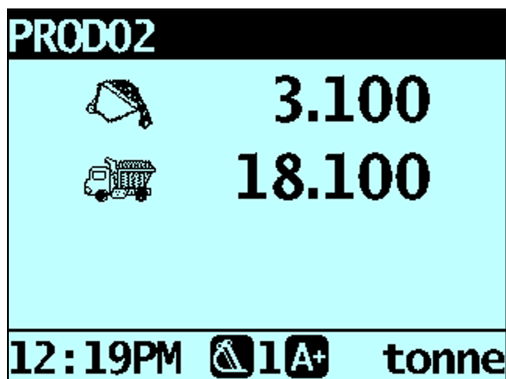

3. Roll the bucket partially forward, tipping product into the truck. The Indicator will give a live weight as it is tipped into the truck.

**IMPORTANT** – Do not raise or lower the lifting arms when tipping, as this will adversely affect the live weight reading. The bucket needs to be rolled back for an accurate weight.

4. When the required truck load weight is reached, press .

**NOTE** – You cannot add a weight while the **Wait...** message is displayed.

5. Move the bucket away from the truck and dump any remaining product.

## 7.2 Stock pile tip-off

Using this method, the operator dumps product from the bucket until it contains the right amount for loading onto the truck.

1. Lift the load in the normal way.  
The Indicator will display the lifted weight.

2. Press .

The **Tip-Off Wait** message will display briefly. Then the screen will display the amount in the bucket and the short total.

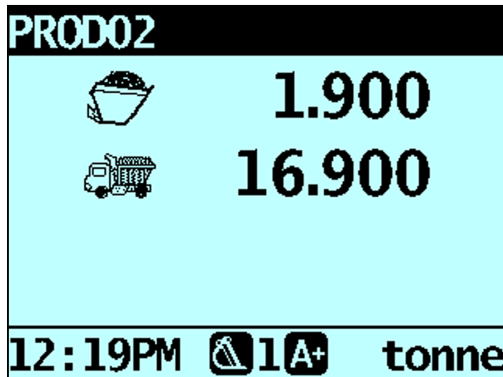

3. Roll the bucket partially forward, dumping the product.  
The Indicator will display the weight in the bucket and the potential weight of the truck.

**NOTE** – Do not raise or lower the lifting arms when tipping, as this will adversely affect the live weight reading. The bucket needs to be rolled back for an accurate weight.

4. Keep dumping the product until the desired weight has been reached, then press .

**NOTE** – You cannot add a weight while the **Wait...** message is displayed.

5. Tip the product from the bucket into the truck.

# 8.0 Advanced Weighing - Tare Weight

**The *Tare Weight* functionality is only available if selected at installation.**

There are two different methods of deducting a tare weight from a load, depending on the way your LOADRITE Weighing System has been set up:

## Tare – Lifted weight

The tare weight can be deducted at the time when the weight is lifted.

For example, if pallets are being used, the weight of a pallet can be entered as the tare weight. The LOADRITE Weighing System will automatically deduct the pallet weight from the lifted weight and displays the net weight of the load.



## Tare – Total weight

The tare weight can be added to the total weight of the load.

For example, if you are loading a vehicle or truck with a known maximum weight, the weight of the vehicle or truck can be entered as the tare weight. The LOADRITE Weighing System will automatically add the tare weight to the total load weight to ensure that the vehicle is not loaded beyond the maximum weight.

## 8.1 How do I enter a tare weight?

To enter a tare weight, complete the following:

1. Press .  
The *Setup Menu* will display.
2. Select **Tare Entry**, then press .  
The *Tare?* screen will display.
3. Use the keypad to enter the required tare weight, then press .

**NOTE** – If the tare weight is **0.000**, less than the set increment size, or is too large, the **Tare Off** message will display before the *Total* screen is displayed.

The **Tare Updated** message will display before the *Total* screen is displayed.

# 9.0 Delay Entry





*Delay Reason Entry functionality is only available if enabled during installation.*



## > Delay Entry

This function is used to display the *Delay Entry* screen so that you can record a reason for a delay to weighing. The reasons for these delays can then be used to generate a report using LOADRITEInsightHQ.

For information on automatically detected delays, see "How do I enter a reason for a delay?" on page 24.

- Either use  to  to select the reason for the delay, OR
- Press  or  to scroll through the delay reasons, then press  to select the reason.

**NOTE** – If a reason is not selected within 10 seconds, the **Other** option will be automatically selected.

The delay will be set and the **Delay** message will display at the top of the screen until the next bucketload is added.



# 10.0 Metrics



> Metrics

## IMPORTANT –

- i) The efficiency rating is for informational purposes only. Trimble Inc makes no warranties and assumes no obligations or liabilities hereunder.
- ii) The *Safe Loading* rating is calculated from the F/Scale (Full Scale) value, which is assumed to have been configured correctly.

The *Metrics* functionality allows you to:

- view your KPI metrics and efficiency ratings from the current workday
- compare your metrics from today with your previous workday, your average performance and your best workday.

## 10.1 Viewing your metrics for today







> Metrics > Today

The *Today* screens display your KPI metrics from the current workday and the efficiency ratings (from 1 to 5 stars):

KPI Metric	Description
Total Wght	The total weight of all bucketloads added today.
Avg Wght/h	The average weight lifted per hour for today.
Load Count	The number of bucketloads successfully added today.
First Load	The time that the first bucketload was added today.
Last Load	The time that the last bucketload was added today.

Efficiency Rating	Description
Zeroing	Your rating for today, based on the number of times you have zeroed the empty bucket. <ul style="list-style-type: none"> <li>■ To improve your score, ensure that you regularly zero the empty bucket throughout the day.</li> </ul>
Efficiency	Your rating for today, based on the number of lifted weights compared to the number of added bucketloads. <ul style="list-style-type: none"> <li>■ To improve your score, reduce the number of underloaded and overloaded buckets over the day.</li> </ul>
Safe Loading	Your rating for today, based on the number of overloaded bucketloads that you have lifted.

Efficiency Rating	Description
	<ul style="list-style-type: none"> <li>To improve your score, reduce the number of overloaded buckets lifted per hour.</li> </ul>
Lift Quality	Your rating for today, based on the number of lift errors. <ul style="list-style-type: none"> <li>To improve your score, reduce the number of lift errors per hour.</li> </ul>



- Press  or  to move between your KPI metrics and your efficiency ratings.
- Press  to print your KPI metrics and efficiency ratings to a local printer (if connected).
- Press  to exit to the *Total* screen.

## 10.2 Comparing your metrics

 > *Metrics* > *Compare*

The *Compare* screens display your metrics from today alongside metrics from your previous workday (**Previous**), your average performance (**Average**) and your best workday (**Best**).

Compare	Description
<b>Total Wght</b>	The total weight of all bucketloads.
<b>Avg Wght/h</b>	The average weight lifted.
<b>Load Count</b>	The number of bucketloads successfully added.

- Press  or  to move between your previous workday, your average performance and your best workday metrics.
- Press  to exit to the *Total* screen.





# 11.0 Printing

The printing options that are available depend on options selected at installation.

Data on the LOADRITE Indicator can be printed immediately, or stored in internal storage for delayed printing. There is normally enough storage for up to one week, depending on usage.

## 11.1 Automatic printing

Depending on your configuration, various weight data is printed either:

- when  is pressed at the end of a load, or
- when , ,  or  is pressed.

The information that is printed depends on settings selected at installation. For further information, contact your LOADRITE distributor.

## 11.2 Printing on demand

The LOADRITE Indicator has a range of options for printing data immediately. Printing options are selected from the *Print Menu*.

### 11.2.1 Print Docket



> *Print Menu* > *Docket*

The *Print Docket* function prints the previous load, which is made up of all data stored (for example, add, subtract) between the last two clear events. If the data is not stored, it will not be printed. For example, if the Indicator is not configured to log add events, weights added will not be printed. This function requires internal storage to be enabled. All configuration of this function is set during installation.

**NOTE** – This function will not work if *Clear* is not used as intended. For example, the operator is loading sand into a truck and half-way through, a second truck arrives. The operator switches product to rocks and starts loading the second truck (without clearing the sand total). When the docket is printed, the added weights of sand plus the added weights and total of rocks will be included.

### 11.2.2 Print Totals



> *Print Menu* > *Totals*

This function prints the total amount of each product loaded that day (since midnight).

## 11.2.3 Print Indicator Data



> *Print Menu > Loadout*

**This printing option is only available if it has been enabled during installation and *Internal Storage* functionality is enabled.**

This function prints out all print data stored in the LOADRITE Indicator memory since midnight (whether or not it has been turned off at any stage during that time).

Depending on the configuration, every add, clear, check zero, etc, could be included in the printout.

## 11.2.4 Print LOADRITE Data Module Data



> *Print Menu > Data Module*

**This printing option is only available if the LOADRITE Data Module has been enabled for logging at installation.**

This function prints out all print data stored in the LOADRITE Data Module since midnight (whether or not it has been turned off at any stage during that time).

Depending on the configuration, every add, clear, check zero, etc, could be included in the printout.

## 11.2.5 Print Special Report





> *Print Menu > Special*

This function allows various reports to be printed from stored data. A series of options are available and the report is created from the options selected.

**TIP** – The *Control* report options can also be accessed directly from a data field screen, for example the *Customer* screen, by pressing . The *Period Options* will display for the selected data value.

### Format Options



Format	Description
Summary	Prints a summary of the selected data.
History	Prints all the selected data.
KPI	Prints the start time, end time, total weight and average weight per hour for each day of the selected period. Average weight per hour is based on cleared weights and the number of hours between the first and last weight of each day.
Control	Prints all dockets for the selected data.

Press  or  to scroll up or down, then press .

The *Period Options* will be displayed.

## Period Options



Format	Description
<b>Today</b>	Prints the report based on data recorded since midnight.
<b>Yesterday</b>	Prints the report based on data recorded for a 24 hour period prior to midnight.
<b>This Week</b>	Prints the report based on data recorded since midnight and the previous six days.
<b>All</b>	Prints the report based on all the data stored (this may have little relevance unless the start time is known).

Press  or  to scroll up or down, then press .

If **Today**, **Yesterday** or **This Week** was selected, the *Group Options* will display. If **All** was selected, the *Port Options* will display.

## Group Options



Format	Description
<b>Totals</b>	The printout is grouped and summarized by product total.
<b>[Data Field 1]</b>	The printout is grouped and summarized by Data Field 1.
<b>[Data Field 2]</b>	The printout is grouped and summarized by Data Field 2.
<b>[Data Field 3]</b>	The printout is grouped and summarized by Data Field 3.

Press  or  to scroll up or down, then press .

If **Totals** was selected, the *Port Options* will display. Otherwise the *Match Options* will display.

## Match Options



Format	Description
<b>All</b>	All values are used on the printout.
<b>One</b>	Only one of the grouped values is reported on. For example, if the printout is grouped by Customer, a report can be generated on one Customer.

Press  or  to scroll up or down, then press .

If **Match All** was selected, the *Load Options* will display. If **Match One** was selected, the specific value must now be selected before the *Load Options* are displayed.

## Load Options



This option determines whether or not the printout will display the number of loads per product. The options are **On** or **Off**.

Press  or  to scroll up or down, then press .

The *Port Options* will display.

## Port Options

Format	Description
Printer	Prints to the LOADRITE printer.
EDP	Captures data to a laptop or Data Module.

Press  or  to scroll up or down, then press .

When the port has been selected, the report will print.

## 11.2.6 Print Summary Report

 > *Print Menu > Summary*

This function prints out a summary report that is grouped and summarized by Data 1. For example, if **Data 1** is a customer field, then this function generates a customer total report using the data stored in the internal memory since midnight.

## 11.2.7 Print Data List

 > *Print Menu > Data List*

This function prints a list of all values from the configured Data Fields (Data 1, Data 2, etc). This function is normally only used to confirm that the values are correct after the list has been updated.

## 11.2.8 Set Number of Copies

 > *Print Menu > Copy*

This function sets the number of dockets to be printed at each clear event.

## 11.2.9 Print Product Names

 > *Print Menu > Product Name*

This function prints out a list of all the product names configured in the LOADRITE system.

**TIP** – This function is normally only used to check the names when the list has been updated.

## 11.2.10 Print Volume Conversion Factors

 > *Print Menu > Volume Conv*

**This printing option is only available if *Volume Conversion Factors* functionality is enabled at installation.**

This function prints out a list of all the product conversion factors configured in the LOADRITE Weighing System. This is normally only used when the list has been updated.

## 11.2.11 Print Standby Message



> *Print Menu* > *Standby*

The LOADRITE weighing system normally displays the service contact details of your local LOADRITE distributor when the Indicator is put into *Standby* mode. These details can also be printed by selecting **Print Standby**.

# 12.0 Internal Storage

The LOADRITE Indicator stores data for delayed printing, printing reports or as a buffer for an absent LOADRITE Data Module. There is normally enough storage for up to one week, depending on usage.

## Usage



> *Internal Stor* > *Usage*

Displays the amount of free storage space remaining in the LOADRITE Indicator internal storage. It also displays the time and date of the first saved event.

## 12.1 Reset



> *Internal Stor* > *Reset*

This function erases all data stored in the LOADRITE Indicator. The time and date of the first entry along with the remaining free space is displayed, before the message **Storage clear?** is displayed.

- Press  to erase the data from memory.



**TIP** – We recommend that you erase the internal storage after reports are generated to prevent duplicate information being included in subsequent reports.



# 13.0 Setup Menu

The *Setup Menu* options that are available depend on options selected at installation.

The *Setup Menu* provides options for configuring the LOADRITE Weighing System.

- To display the *Setup Menu*, press . Press  or  to scroll up or down, then press  to select an option.
- To exit the *Setup Menu*, press .

Menu Option	Description
Setup...	Displays the <i>Install Menu</i> . For further information, contact your LOADRITE distributor.
Auto-Add	Select whether or not <i>Auto-Add</i> is enabled.
Tare Entry	Allows a tare value to be entered.
Unit Toggle	Select between two units of weight.
Trig Screen	Select whether the trigger position graphic is displayed.
Language	Select the language for the Indicator.
Edit Password	Change the login PIN number.
Scale#	Select the attachment.
Module	Displays the <i>Data Module</i> screen.
Data Edit	Select the data value for the data field.
Data List	Edit data values.
Clock	Displays the <i>Clock</i> screen.
Display	Allows configuration of the <i>Total</i> and <i>Target</i> screens, and the screen backlight and contrast levels.
Long Total	Displays the <i>Long Total</i> screen.
ClearAll	Clears the <i>Long Total</i> for all products.
Selftest	Runs a system self-test.
Uplink	Allows the Indicator to communicate with the <i>LOADRITE Toolbox</i> PC software.
Standby	Puts the Indicator into <i>Standby</i> mode

## 13.1 Setup...

Displays the *Security Code* screen for entering an access code. The *Install Menu* and a range of other menus can be accessed, depending on the access code that is entered.

- For further information, contact your LOADRITE dealer.

## 13.2 Auto-Add

Controls whether or not the *Auto-Add* functionality is enabled.

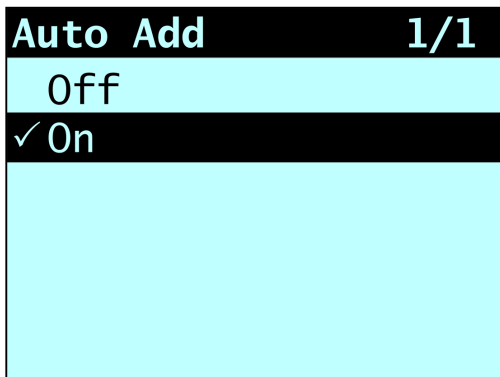

- Select either **On** or **Off**, then press .

## 13.3 Tare Entry

Allows you to enter a tare weight value. To enter a tare weight, complete the following:



- Use the keypad to enter the required tare weight, then press .

**NOTE** – If the tare weight is **0.000**, less than the set increment size or is too large, the **Tare Off** message will display before the *Total* screen is displayed.

The **Tare Updated** message will display before the *Total* screen is displayed.

## 13.4 Unit Toggle

The LOADRITE Indicator can store up to two units of weight and you can use the **Unit Toggle** option to switch between them. The current weight will be displayed in the current weight unit and in the other available weight unit.

- To confirm the change to the other weight unit, press .
- To keep the current weight unit, press .

## 13.5 Trig Screen

Controls whether the loader position graphic is displayed.

- Select either **On** or **Off**, then press .

## 13.6 Language

**The language can only be changed if *Language Edit* functionality has been enabled during installation.**

Displays a list of available languages in which the LOADRITE Indicator can display screen names, fields, menu options and printed dockets.

- Select your preferred language, then press .

## 13.7 Edit Password

**A password can only be edited if *Login* functionality has been enabled during installation.**

Allows the PIN number of the current operator to be changed using the keypad.

- Enter the new PIN number using the keypad, then press .

## 13.8 Scale #

**The Scale options are only available if *Multiple Scales* functionality has been enabled during installation.**

This option enables the use of different load bearing implements (for example, bucket or forks) on the loader. The operator needs to select the correct scale for the attached implement.

**TIP** – You should perform a *Check Zero* after changing the attachment.

## 13.9 Module

**The *Module* option is only available if a LOADRITE Data Module is connected to the Indicator and *Data Logger* functionality has been correctly configured during installation.**





The *Data Module Menu* provides functionality for use with LOADRITE Data Modules.

The following menu items are available:

Option	Description
Property	Lists the properties of the Data Module.
Backup	Saves the product list and data lists to the Data Module.
Restore	Uploads data stored on the Data Module to the LOADRITE Indicator. This can be used to share data between Indicators.

## 13.10 Data Edit



Allows you to select a value for each data field:



1. Press .  
The *Setup Menu* will display.
2. Select **Data Edit**, then press .  
The *Data Edit* screen for the first data field will display.
3. Use  or  to select the required data value for the data field, then press .  
The *Data Edit* screen for the next data field will display.
4. Repeat steps 2-3 until data values have been selected for all data fields.



## 13.11 Data List

### 13.11.1 Adding a data value





**NOTE** – Data field values can only be entered using specific *Western Latin* characters, such as in English.

1. Press .  
The *Setup Menu* will display.
2. Select **Data List**, then press .  
The *Edit?* screen will display.
3. Complete the following:

If...	Then...
you would like to add a data value to the data field that is displayed	press  .
you would like to select a different data field	press  until the required data field is displayed, then press  .

4. Press .  
The *Data Entry* screen will display.
5. Use the keypad to enter the data value, then press .
6. Complete the following:

If...	Then...
you would like to add another data value	<ul style="list-style-type: none"> <li>■ Go back to step 4.</li> </ul>

If...	Then...
you would like to select a different data field	<ul style="list-style-type: none"> <li>Press .</li> <li>press  until the required data field is displayed, then press .</li> <li>Go back to step 4.</li> </ul>
you have finished editing data values	Press  twice to return to the <i>Setup Menu</i> .

## 13.11.2 Editing a data field value

You can edit a data field value if required by using the *Data List* function.



**NOTE** – Data field values can only be entered using specific *Western Latin* characters, such as in English.



1. Press .  
The *Setup Menu* will display.

2. Select **Data List**, then press .  
The *Edit?* screen will display.



3. Complete the following:







If ...	Then ...
you would like to edit a data value from the data field that is displayed	press  .
you would like to select a different data field	press  until the required data field is displayed, then press  .

4. Press  or  to scroll up or down the list of data values until the required data value is displayed, then press .  
The *Data Entry* screen will display.

5. Use the keypad to edit the data value, then press .

**TIP** – Press  to clear the current value name.

6. Complete the following:

If ...	Then ...
you would like to edit another data value	<ul style="list-style-type: none"> <li>Press  until the required data value is displayed, then press .</li> <li>Go back to step 4.</li> </ul>
you would like to select a different data field	<ul style="list-style-type: none"> <li>Press .</li> <li>press  until the required data field is displayed, then press .</li> <li>Go back to step 5.</li> </ul>
you have finished editing data values	Press  twice to return to the <i>Setup Menu</i> .

## 13.12 Clock

The time, date and year can only be changed if *Clock Edit* functionality has been enabled during installation.



You can set the time, date and year on the Indicator.

### 13.12.1 Setting the time

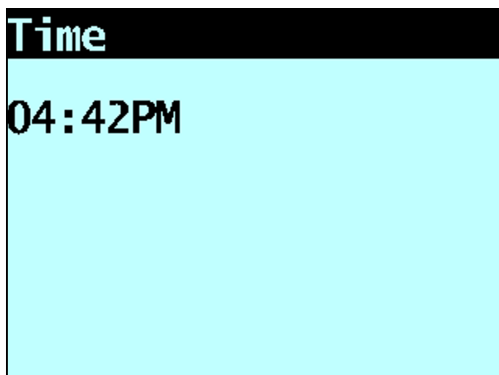

1. From the *Clock Menu* select **Time**, then press . The time will display with the cursor over the first digit.





2. Use the keypad to enter the time:

- Press  or  to select **AM** or **PM**.
- Press  to confirm the new time.

## 13.12.2 Setting the date

1. From the *Clock Menu* select **Date**, then press .
2. Use the keypad to enter the month and day:
  - a. Press **1-9** for **January** to **September**; Press **0** then **0** for **October**; Press **0** then **1** for **November**; Press **0** then **2** for **December**.
  - b. Press  to confirm the new date.

## 13.12.3 Setting the year

1. From the *Clock Menu* select **Year**, then press .
2. Use the keypad to enter the last two digits of the year. For example, press **1** then **6** for **2016**.
3. Press  to confirm the new year.

## 13.12.4 Alarm

This option turns the alarm clock **On** or **Off**. When the alarm time is reached, the following will occur:

- an alert tone will sound,
- the **Alarm Clock** message will display,
-  (**Trigger light**) will flash.





The alarm will stop after a few seconds or when any button is pressed.

The alarm clock will alert when the Indicator is in *Ready* or *Standby* mode. The alarm clock will not alert if the Indicator is turned off.

## 13.12.5 Alarm time

This option changes the alarm time.

**NOTE** – The alarm will only alert if the **Alarm** option is set to **On**.





1. From the *Clock Menu* select **Alarm Time**, then press .  
The alarm time will display with the cursor over the first digit.
2. Use the keypad to enter the time.
3. Press  or to  select **AM** or **PM**.
4. Press  to confirm the new alarm time.

## 13.13 Display

This option allows the display to be configured. The following menu items are available:





### 13.13.1 Changing the screen brightness

To change the brightness of the display screen, complete the following:

1. From the *Display Menu* select **Light**, then press .
2. Press  -  to select the desired brightness level.
3. Press  to save the brightness level.

### 13.13.2 Changing the screen contrast



To change the contrast of the display screen, complete the following:





1. From the *Display Menu* select **Contrast**, then press .
2. Press  -  to select the desired contrast level.
3. Press  to save the contrast level.

### 13.13.3 Selecting Arm Graphic

To select whether the loader graphic or bar graph displays on the *Total* screen, complete the following:

**NOTE** – The loader graphic will only be displayed if the *Total* screen layout is set to **Classic**. If the *Total* screen layout is set to **Compact** or **Scroll**, the bar graph will display.

1. From the *Display Menu* select **Arm Graphic**, then press .
2. Press  or  to select **Loader** or **Bar Graph**.





If you would like to...	Then...
the loader graphic to display on the <i>Total</i> screen	press  or  to select <b>Loader</b> .
the bar graph to display on the <i>Total</i> screen	press  or  to select <b>Bar Graph</b> .

3. Press  to save the arm graphic selection.







## 13.13.4 Changing the Total screen layout

There are three layouts available for the *Total* screen. To change the layout, complete the following:

1. From the *Display Menu* select **Ready Screen**, then press .
2. Press  or  to select your preferred *Total* screen layout.
3. Press  to save your layout selection.

## 13.13.5 Changing the Target screen layout

There are two layouts available for the *Target* screen. To change the layout, complete the following:

1. From the *Display Menu* select **Target**, then press .
2. Press  or  to select your preferred *Target* screen layout.
3. Press  to save your layout selection.

## 13.14 Long total

View and clear the long total for current products.

- For more information, see "*View and clear the long total*" on page 30.

## 13.15 Clear all

Allows you to clear the long total for all products.

- For more information, see "*View and clear the long total*" on page 30.

## 13.16 Self test



This function tests various functions and the internal memory. All tests are run automatically when this option is selected. When the test has completed, the *Total* screen will display.

## 13.17 Uplink



This option is used to upload a configuration file created using *LOADRITE Toolbox* via a LOADRITE Data Module or from a PC via a EDP cable. The configuration file contains product names, data lists and settings.

- For information on creating a configuration file, refer to the *LOADRITE Toolbox User Manual*.

### 13.17.1 Uploading a configuration file via a EDP cable

1. From the *Uplink Menu* select **EDP**, then press .  
The Indicator will enter *Uplink* mode.
2. When the message **Uplink Ready** is displayed, use *LOADRITE Toolbox* to send the configuration file.
  - The message **Updating** and a counter will display as the Indicator receives the configuration file.
  - *LOADRITE Toolbox* will display a message to indicate that the upload is complete.
3. Press  to exit *Uplink* mode.

### 13.17.2 Uploading a configuration file via a LOADRITE Data Module

1. From the *Uplink Menu* select **Data Module**, then press .
2. Connect the LOADRITE Data Module containing the configuration file to the Indicator.
3. When the **Sync Config From Module?** message displays, press .  
A counter will display as the Indicator receives the configuration file.
4. When the **Delete Config From Module?** message displays, press .  
The configuration file will be deleted from the Data Module.

## 13.18 Standby

This option puts the Indicator into *Standby* mode. The Indicator will also go into *Standby* mode if it is not used for two hours.

- Press any button to exit *Standby* mode.

# 14.0 Appendix A: System Specifications

Specification	Value
<b>Input voltage</b>	7.0 - 32.0 V DC
<b>Current Consumption (typical)</b>	Active, no RF transmission: 233 mA at 12V DC Active, with RF transmission: 275 mA (400 mA peak) at 12 V DC Low power standby mode: <8 mA at 12 V DC
<b>Inputs and outputs</b>	1 Serial port RS-232 – connect to scale
<b>Enclosure material</b>	Aluminum
<b>Dimensions</b>	(WxDxH) 230mm x 136.3mm x 40mm (9.05 in x 5.37 in x 1.57 in)
<b>Weight</b>	1.09kg (2.4 lbs)
<b>Connectors</b>	Multi: 34 Pin male positive locking GPS Antenna.: SMA Jack LTE Antennas: TNC, RP-SMA Jack WLAN: RP TNC Jack
<b>Temperature</b>	Operating: -30°C to +85°C (-22°F to +185°F) Storage: -40°C to +85°C (-40°F to +185°F)
<b>Humidity</b>	SAE J1455
<b>Shock</b>	SAE J1455
<b>Vibration operating</b>	SAE J1455
<b>Environmental protection</b>	IP67
<b>Cellular communications</b>	LTE, 3G, 4G and GSM (EGPRS, GPRS)
<b>Positioning</b>	A-GPS Receiver: Qualcomm GPSOne Type: 12 channel; L1 C/A Code, Continuous Tracking Horizontal Accuracy: <2 m (50% CEP) Maximum Update Rate: 1 Hz Tracking Sensitivity: -159 dBm Acquisition Sensitivity: -149 dBm Time to Position (typical): <ul style="list-style-type: none"> <li>■ Cold start: 25 seconds</li> <li>■ Warm start: 10 seconds</li> <li>■ After 15 second signal blockage: &lt; 2 seconds</li> </ul>

Specification	Value
Status indicators	External tri-color LEDs: <ul style="list-style-type: none"> <li>■ Green: Power and GPS Status</li> <li>■ Blue: Wireless Communications Status (Cellular)</li> </ul>
Certifications	A-Tick; CE; E-mark; FCC Class B Part 15; Industry Canada Class B; RoHS; WEEE.

## 14.1 Weighing accuracy

Typical accuracy is within  $\pm 1\%$  for most bucket loaders. This may vary with different machine types, installation options, and the operating environment.

## 14.2 Minimal weighing delay

Weighing delay is minimal, because the weighing function is carried out during a normal lift.

## 14.3 Power requirements

Supply voltage	12V to 32V DC
Supply current	LOADRITE Indicator: 160mA typical; 350mA max. LOADRITE printer: 50mA standby, 4A peak.
Automatic transient suppression	Exceeds relevant SAE specifications for DC automotive power supply transients.

## 14.4 Physical specifications

LCD display	Backlit; 3.8in (diagonal); QVGA.
Tactile keypad	Backlit; Numeric and special functions.
Weight	1.5 kg (3.2lb)
Dimensions	W145 x L240 x D110mm (5.7 x 9.4 x 4.3in)

## 14.5 Environmental specifications

<b>Operating temperature</b>	-10°C ~ 50°C (14°F ~ 122°F)
<b>Tactile keypad</b>	-50°C ~ 100°C (-58°F ~ 212°F)
<b>Weight</b>	Protected to IP54.
<b>Dimensions</b>	Protected to IP69.

The Indicator wear-out mechanisms have been evaluated and improved through several iterations of cyclic thermal stress between -90°C and +110°C with simultaneous 6-axis random, repetitive shock exceeding 50Grms.

## 14.6 Signal inputs and outputs

<b>Pressure transducer input</b>	4 - 20mA (0-100%)
<b>Trigger</b>	Trigger 1: Magnetic or Optical. Pull-up resistor with switch to ground. Trigger 2: Rotary. Pulse width modulated 0-5V.
<b>Serial communications</b>	RS232C protocol to printer and LOADRITE Data Module.

## 14.7 Clock

<b>Built-in clock</b>	Hours, minutes, day, month, year.
-----------------------	-----------------------------------

## 14.8 Output / Input connections

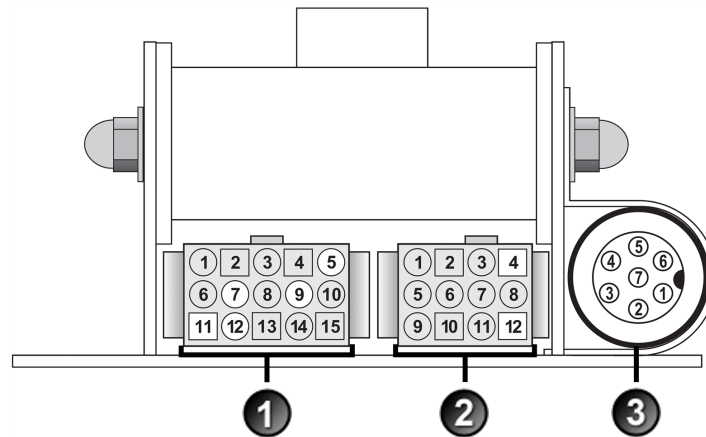

	Connection
1	Power / Control
2	Printer / Data Logger
3	Pressure Transducer

### 14.8.1 Power / Control

1. Negative supply (ground)	2. Positive supply
3. Remote button 2 (clear)	4. Remote button 1 (add)
5. Tilt sensor 1	6. Tilt sensor 3
7. Tilt sensor 2	8. +VAUX
9. Digital out	10. Boom position
11. Stick position	12. CAN hi
13. CAN lo	14. +V raw
15. Ground output	

### 14.8.2 Printer / Data Logger

1. Negative supply to printer	2. Positive supply to printer
3. +VAUX	4. RX2
5. TX2	6. Printer RS232 output
7. Printer busy input	8. LOADRITE Data Module RS232 input
9. LOADRITE Data Module RS232 output	10. Ground output
11. Boot	12. N.C.

### 14.8.3 Pressure Transducer

1. +VAUX	2. Return pressure input
3. Transducer current input	4. +VAUX
5. Lift pressure input	6. Shield
7. Ground	





# 15.0 Appendix B: Span Calibration Adjustment

This function allows small changes to be made to the LOADRITE Weighing System calibration if the bucket is modified, or if no accurate test weight was available when the LOADRITE Weighing System was calibrated at installation time.

The adjustment is carried out by entering the total weight recorded at a weighbridge (scale house) and the corresponding total provided by the LOADRITE Indicator.

To perform the adjustment, a security access code must be obtained from your LOADRITE installer.

 **CAUTION** – The LOADRITE Weighing System alters its calibration every time this function is used. It is important that this function is only used once with a given set of data. If the same weights are entered again, the LOADRITE Weighing System will over-correct and its accuracy will be seriously impaired.

1. Press .
2. Select **Setup...**, then press .
3. Enter the security access code provided by the LOADRITE installer, then press .
4. Select **Calibration Menu**, then press .  
The *Calibration Menu* will display.
5. Select **Adjust Span**, then press .
6. The **Adjust Span** message will display briefly and then the *LOADRITE Adjust Span* screen will display.



7. Enter the total weight provided by the weighbridge, then press .

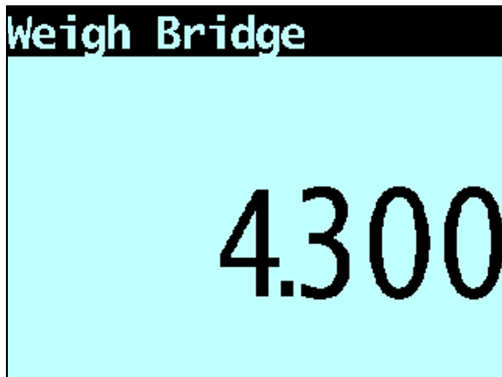

8. The LOADRITEIndicator briefly displays the **Calibration Updated** message, and then returns to the *Calibration Menu*.

9. Enter the total weight provided by the LOADRITEIndicator, then press .

## 15.1 Checking the adjustment

The *Span Calibration Adjustment* can be checked by obtaining and comparing new LOADRITE and weighbridge values. If necessary, the *Span Calibration Adjustment* can be performed again using the new data.

**NOTE** – All trucks and trailers should have tare weights confirmed for all loads to be checked. This ensures that a true weight can be established. Avoid split-weighing the truck and trailer.



# 16.0 Appendix C: Error Messages

Error messages may be displayed for a variety of reasons as detailed below:

## 16.1 Bouncing load

If the lift arms are bouncing significantly while weighing, an error occurs. This can happen if, for example, the loader is driven over uneven ground while lifting the load.

Depending on the installation of the particular LOADRITE Weighing System, there are two possibilities:

- No weight is displayed and therefore there is no weight to add. Repeat the lift.
- *Weighing Error* is turned off and a weight is displayed. Add the weight to the total (bearing in mind that the weight measurement is not reliable) or ignore this weight and repeat the lift smoothly.

## 16.2 Bucket back?

The bucket must be crowed fully back for each lift. The **Bucket back?** message will be displayed if the LOADRITE Weighing System has not detected that the bucket is fully crowded back.

**NOTE** – This message should only be displayed when using a Legal for Trade scale.

## 16.3 Bucket empty?

If the bucket is zeroed and there is some residue in the bucket, the LOADRITE Weighing System will detect how much is in the bucket. If the contents are less than 5% of the full bucket capacity, the LOADRITE Weighing System will zero the bucket. If the weight of product in the bucket is within 5-10% of full bucket capacity, the Indicator will display the **Bucket Empty?** message to confirm the zero.

- To zero the bucket, press .

## 16.4 Bucket not back

The bucket must be crowed fully back for each lift. The **Bucket not back** message will be displayed if the LOADRITE Weighing System has not detected that the bucket is fully crowded back.

**NOTE** – This message should only be displayed when using a Legal for Trade scale.

## 16.5 Calibration Reminder

This message displays on start-up as a reminder that a calibration is due to be performed on the LOADRITE Weighing System. Depending on the configuration of the Indicator, the reminder may also display when in *Standby* mode.

**NOTE** – This message should only be displayed if *Calibration Reminder* functionality has been enabled and configured at installation.

## 16.6 Check power

The power supply has reached an unstable level. Check that the power source is stable and between +12V and +32V.

## 16.7 Check MAG/OPT

There is a fault in the magnetic or optical trigger or the cable that connects the trigger. If using an optical trigger, check that the lens is clear and dust-free.

## 16.8 Check rotary

There is a fault in the rotary trigger or the cable that connects the trigger. Check that the trigger is still securely mounted and that the trigger finger has not been damaged.

## 16.9 Check scale#

This message displays when  is pressed if the Indicator is set up for use with multiple scales.

If the weight is greater than 10% of full bucket capacity for the selected scale number, the screen displays **Check Scale#** message. The operator needs to ensure the correct scale number is selected for the attached implement, as implements differ considerably in weight.

## 16.10 Check tilt

There is a fault in the tilt sensor used for ground slope compensation or the cable that connects the sensor. Check that the tilt sensor is still securely mounted and that the cable has not been damaged.

## 16.11 Check transducer

There is an error in the pressure transducer signal input. This indicates a fault in either the pressure transducer or the cable that connects the transducer.

## 16.12 Check zero

The operator is automatically reminded to zero the bucket.

## 16.13 Lift under range

The lift pressure was too low. This indicates a fault in either the pressure transducer or the cable that connects the transducer.

## 16.14 Low battery

The Indicator internal battery power is low and must be replaced. The Low Battery message will display and a long 'beep' will sound at start-up or when exiting *Standby Mode*. Contact your LOADRITE distributor to arrange for a replacement battery.

 **CAUTION** – If this message is ignored, the Indicator will enter *Low Battery Safe Mode*, during which all product names, data fields and loading history will be deleted and all configuration options will be reset to the default values. Calibration data is not affected, so the Indicator may still be used for accurate weighing.

## 16.15 Need emptying

The bucket must be crowded fully forward to ensure that all product has been emptied. The **Need Emptying** message will be displayed if the LOADRITE Weighing System has not detected that the bucket has been crowded fully forward.

**NOTE** – This message should only be displayed when using a Legal for Trade scale.

## 16.16 No lock

The interlock was not closed when lifting the load. The interlock must be closed (or the bucket must be fully rolled back) while lifting the load. No weight is displayed and therefore there is no weight to add.

## 16.17 Num Attempts Exceeded

This message displays if the number of attempts to perform a check zero is exceeded when FACT is activated. The number of attempts is set during installation.

## 16.18 Over target

Adding the lifted weight will exceed the target value. The lifted weight can still be added by pressing .

**NOTE** – The *Auto-add* function will not automatically add over-target weight.

## 16.19 Overload

The lifted weight exceeds the full scale (capacity) setting. If the *Overload Error* is set during installation, overloaded weight cannot be added.

## 16.20 Pitch too high

The angle of the loader is at an unsafe pitch (front/back tilt) while weighing. If this message is displayed, the weight cannot be added. The safe pitch angle is set during installation.

**NOTE** – This message should only be displayed if the Ground Slope Compensation module is installed.

## 16.21 Poor lift

If a weighing error is close to, but not greater than, the tolerance limit, the LOADRITE Indicator displays this warning message. The weight can be added as usual.

## 16.22 Printer disabled

Print function has been disabled at installation.

## 16.23 Printer error

There is a fault in the printer. Check that the printer is online and has paper.

## 16.24 Return under range

The return pressure was too low. This indicates a fault in either the pressure transducer or the cable that connects the transducer.

## 16.25 Roll too high

The angle of the loader is at an unsafe roll (left/right tilt) while weighing. If this message is displayed, the weight cannot be added. The safe roll angle is set during installation.

**NOTE** – This message should only be displayed if the Ground Slope Compensation module is installed.

## 16.26 Speed changed

For accurate measurement, the speed of raising the lift arms must be smooth, without acceleration or deceleration. The LOADRITE Weighing System can detect changing speed as the arms go past the Trigger Point. Depending on the installation of the LOADRITE Weighing System, there are two possibilities:

- No weight is displayed, and therefore there is no weight to add. Repeat the lift and avoid accelerating and decelerating at or near the Trigger Point.
- A weight is displayed. Add weight to the total (acknowledging that the weight measurement is not reliable) or ignore this weight and repeat the lift smoothly.

## 16.27 Speed too high

This message displays if the speed of raising the arms is too fast and exceeds predefined limits.

Lift the arms again slower. If the message displays again, there may be a fault in the system. The LOADRITE Weighing System should be checked and, if necessary, re-calibrated.

## 16.28 Tilt too high

The angle of the loader is at an unsafe roll or pitch while weighing. The **Tilt Too High** message accompanies the specific roll or pitch error at the top bar of the display.

## 16.29 Too heavy, zero aborted

If the weight of product in the bucket is greater than 10% of full bucket capacity when  is pressed, the screen displays this message and does not alter any settings. This prevents any accidental zeroing of valid weights.

**NOTE** – If the bucket is empty and the message still occurs, there may be a fault in the system. The LOADRITE Weighing System should be checked and, if necessary, re-calibrated.

## 16.30 Warm-up lift

This message displays if the Indicator has been turned off for more than one hour, prompting a warm-up lift.

# 17.0 Appendix D: Legal Information

## Disclaimer

Trimble Inc operates a policy of on-going development. Please note that while every effort has been made to ensure that the data given in this document is accurate, due to continued product development, the information, figures, illustrations, tables, specifications, and schematics contained herein are subject to change without notice. Trimble Inc does not warrant that this document is error-free. The screenshots and other presentations shown in this manual may differ from the actual screens and presentations generated by the actual product. All such differences are minor and the actual product will deliver the described functionality as presented in this document in all material respects. If you find any errors in the document, please report them to us in writing. Trimble Inc assumes no liability in connection with the use of any LOADRITE branded product.

Trimble Inc is not responsible for any radio or TV interference caused by unauthorized modifications to this equipment. Such modifications could void the user's authority to operate the equipment.

## Compliance

Domain	Applicable Standard
Immunity Standards (industrial)	IEC 61000-4-3 (ed1.2) Electromagnetic compatibility (EMC) - Part 4-3: Testing and measurement techniques - Radiated, radio-frequency, electromagnetic field immunity test (80% 1kHz Amplitude Modulated) from 80MHz to 1GHz 10V/m IEC 61000-4-3 (ed1.3) Electromagnetic compatibility (EMC) - Part 4-3: Testing and measurement techniques - Radiated, radio-frequency, electromagnetic field immunity test (80% 1kHz Amplitude Modulated) from 1.4GHz to 2GHz 3V/m IEC 61000-4-3 (ed1.4) Electromagnetic compatibility (EMC) - Part 4-3: Testing and measurement techniques - Radiated, radio-frequency, electromagnetic field immunity test (80% 1kHz Amplitude Modulated) from 2GHz to 2.7GHz 1V/m
Conducted	IEC 61000-4-6 (ed2.1) Electromagnetic compatibility (EMC) - Part 4-6: Testing and measurement techniques - Immunity to conducted disturbances, induced by radio-frequency fields
Fast Transients	IEC 61000-4-4 (ed2.1) Electromagnetic compatibility (EMC) - Part 4-4: Testing and measurement techniques - Electrical fast transient/burst immunity test +/-1kV (5/50 Tr/ns - 5kHz repetition)
ESD	IEC 61000-4-2 Electromagnetic compatibility (EMC) - Part 4-2: Testing and measurement techniques - Electrostatic discharge immunity test +/-4kV / Electrostatic Air Discharge +/-8kV
Electromagnetic compatibility (EMC)	EN/IEC/ASNZS 61000-6-2:2005 Electromagnetic compatibility (EMC) - Part 6-2: Generic standards - Immunity for industrial environments EN/IEC 61000-6-4:2005 Electromagnetic compatibility (EMC) - Part 6-4: Generic Standards - Emission standard for industrial environments ANSI C63.4:2003 FCC Part 15 (A and B) - Radio Frequency Devices



Products with the CE marking comply with the Electromagnetic Compatibility Directive (2004/108/EC) issued by the Commission of the European Community. Compliance with this directives implies conformity to the following European Standards: EN 61000-6-2:2005 Electromagnetic compatibility (EMC) - Part 6-2: Generic standards - Immunity for industrial environments  
EN 61000-6-4:2005 Electromagnetic compatibility (EMC) - Part 6-4: Generic Standards - Emission standard for industrial environments

This LOADRITE product is fully EMC (Electro-Magnetic Compatibility) compliant and is CE marked accordingly. A Declaration of Conformity, in accordance with the EMC Directive 89/336/EEC (and as amended) is available from Trimble Inc on request: [info@loadritescales.com](mailto:info@loadritescales.com)

Trimble Inc cannot be held responsible for modifications made by the User and the consequences thereof, which may alter the conformity of the product with CE marking.

Hereby, Trimble Inc, declares that this LOADRITE L2180 is in compliance with the essential requirements and other relevant provisions of Directive 2004/108/EC.

This LOADRITE product is explicitly excluded from the scope of EU RoHS 2 Directive 2011/65/EU in article 2, section (4), paragraphs: (d), (e), (f) and (g).

This device complies with part 15 of the FCC Rules and Industry Canada licence-exempt RSS standard(s). Operation is subject to the following two conditions: (1) This device may not cause harmful interference, and (2) this device must accept any interference received, including interference that may cause undesired operation.

This Class A digital apparatus complies with Canadian ICES-003 (A) / NMB-003 (A).



**WARNING** – This product contains chemicals known to the State of California to cause cancer, birth defects or other reproductive harm. This Notice is being provided in accordance with California's Proposition 65.

## Disposing of LOADRITE electronic equipment

This electronic product is subject to the EU Directive 2002/96/EC for Waste Electrical and Electronic Equipment (WEEE) which requires the separate collection, treatment, recycling and environmentally-sound final disposal of waste of electrical and electronic equipment. As such, this product must not be disposed of at a municipal waste collection point.

Please refer to local regulations for directions on how to dispose of this product in an environmentally-friendly manner.



# Notes





---

45 Patiki Road, Avondale, Auckland 1026  
PO Box 19623, Avondale, Auckland 1746  
New Zealand  
Tel: +64 9 820 7720  
Fax: +64 9 820 7721

